

SOKKIA

GRX2 GNSS Receiver



Operator's Manual



GRX2

Operator's Manual

Part Number 1001826-01

Rev B

ECO#000340

©Copyright Topcon Positioning Systems, Inc.

December, 2012

All contents in this manual are copyrighted by Topcon Positioning Systems, Inc. All rights reserved.

Preface



Thank you for purchasing this Sokkia product. The materials available in this Manual (the “Manual”) have been prepared by Topcon Positioning Systems, Inc. (“TPS”) for owners of Sokkia products, and are designed to assist owners with the use of the receiver and its use is subject to these terms and conditions (the “Terms and Conditions”).



Please read the terms and conditions carefully.

Terms and Conditions Use

This product is designed to be used by a professional. The user should have a good knowledge of the safe use of the product and implement the types of safety procedures recommended by the local government protection agency for both private use and commercial job sites.

Copyrights

All information contained in this Manual is the intellectual property of, and copyrighted material of TPS. All rights are reserved. Do not use, access, copy, store, display, create derivative works of, sell, modify, publish, distribute, or allow any third party access to, any graphics, content, information or data in this Manual without TPS’ express written consent and may only use such information

for the care and operation of the receiver. The information and data in this Manual are a valuable asset of TPS and are developed by the expenditure of considerable work, time and money, and are the result of original selection, coordination and arrangement by TPS.

Trademarks

GRX™, SRU™, Magnet™, Pocket-3D™, Sokkia® and Topcon Positioning Systems™ are trademarks or registered trademarks of TPS. Windows® is a registered trademark of Microsoft Corporation. The Bluetooth® word mark and logos are owned by Bluetooth SIG, Inc. and any use of such marks by Topcon Positioning Systems, Inc. is used under license. Other product and company names mentioned herein may be trademarks of their respective owners.

Disclaimer of Warranty

EXCEPT FOR ANY WARRANTIES IN AN APPENDIX OR A WARRANTY CARD ACCOMPANYING THE PRODUCT, THIS MANUAL AND THE RECEIVER ARE PROVIDED “AS-IS.” THERE ARE NO OTHER WARRANTIES. TPS DISCLAIMS ANY IMPLIED WARRANTY OF MERCHANTABILITY OR FITNESS FOR ANY PARTICULAR USE OR PURPOSE. TPS AND ITS DISTRIBUTORS SHALL NOT BE LIABLE FOR TECHNICAL OR EDITORIAL ERRORS OR OMISSIONS CONTAINED HEREIN; NOR FOR INCIDENTAL OR CONSEQUENTIAL DAMAGES RESULTING FROM THE FURNISHING, PERFORMANCE OR USE OF THIS MATERIAL OR THE RECEIVER. SUCH DISCLAIMED DAMAGES INCLUDE BUT ARE NOT LIMITED TO LOSS OF TIME, LOSS OR DESTRUCTION OF DATA, LOSS OF PROFIT, SAVINGS OR REVENUE, OR LOSS OF THE PRODUCT’S USE. IN ADDITION TPS IS NOT RESPONSIBLE OR LIABLE FOR DAMAGES OR COSTS INCURRED IN CONNECTION WITH OBTAINING SUBSTITUTE PRODUCTS OR SOFTWARE, CLAIMS BY OTHERS, INCONVENIENCE, OR ANY OTHER COSTS. IN ANY EVENT, TPS SHALL HAVE NO LIABILITY FOR DAMAGES OR OTHERWISE TO YOU OR ANY OTHER PERSON OR ENTITY IN EXCESS OF THE PURCHASE PRICE FOR THE RECEIVER.

License Agreement

Use of any computer programs or software supplied by TPS and Sokkia or downloaded from a Sokkia website (the “Software”) in connection with the receiver constitutes acceptance of these Terms and Conditions in this Manual and an agreement to abide by these Terms and Conditions. The user is granted a personal, non-exclusive, non-transferable license to use such Software under the terms stated herein and in any case only with a single receiver or single computer. You may not assign or transfer the Software or this license without the express written consent of TPS. This license is effective until terminated. You may terminate the license at any time by destroying the Software and Manual. TPS may terminate the license if you fail to comply with any of the Terms or Conditions. You agree to destroy the Software and manual upon termination of the use of the receiver. All ownership, copyright and other intellectual property rights in and to the Software belong to TPS. If these license terms are not acceptable, return any unused software and manual.

Confidentiality

This Manual, its contents and the Software (collectively, the “Confidential Information”) are the confidential and proprietary information of TPS. You agree to treat TPS’ Confidential Information with a degree of care no less stringent than the degree of care you would use in safeguarding your own most valuable trade secrets. Nothing in this paragraph shall restrict you from disclosing Confidential Information to your employees as may be necessary or appropriate to operate or care for the receiver. Such employees must also keep the Confidentiality Information confidential. In the event you become legally compelled to disclose any of the Confidential Information, you shall give TPS immediate notice so that it may seek a protective order or other appropriate remedy.

Website; Other Statements

No statement contained at the TPS and Sokkia websites (or any other website) or in any other advertisements or TPS literature or made by an employee or independent contractor of TPS modifies these Terms and Conditions (including the Software license, warranty and limitation of liability).

Safety

Improper use of the receiver can lead to injury to persons or property and/or malfunction of the product. The receiver should only be repaired by authorized TPS warranty service centers. Users should review and heed the safety warnings in an Appendix.

Miscellaneous

The above Terms and Conditions may be amended, modified, superseded, or canceled, at any time by TPS. The above Terms and Conditions will be governed by, and construed in accordance with, the laws of the State of California, without reference to conflict of laws.

Manual Conventions

This manual uses the following conventions:

Convention	Description	Example
Bold	Menu, or drop-down menu selection Name of a dialog box or screen Button or key commands	File ▶ Exit (Click the File menu and click Exit) From the Connection screen... Click Finish .
<code>Mono</code>	User supplied text or variable	Type <code>guest</code> , and click Enter .
<i>Italic</i>	Reference to another manual or help document	Refer to the <i>Sokkia Reference Manual</i> .



Further information to note about system configuration, maintenance, or setup.



Supplementary information that can have an adverse affect on system operation, system performance, data integrity, measurements, or personal safety.



Notification that an action has the potential to result in system damage, loss of data, loss of warranty, or personal injury.

Table of Contents

•••••

Terms and Conditions Use	i
Copyrights	i
Trademarks	ii
Disclaimer of Warranty	ii
License Agreement	iii
Confidentiality	iii
Website; Other Statements	iv
Safety	iv
Miscellaneous	iv
Manual Conventions	v
GRX2 Features	2
Unpacking Your Receiver Kit	3
System Components	3

Accessories	4
Technical Documents	4
Using Sokkia Software With Your Receiver	5
Getting Technical Support	6
Website	7
Phone	7
Receiver Overview	8
Cables	10
Memory	12
Detachable Batteries	13
Voice Notification	13
Data and Power Ports	15
External Radio Antenna Connector	16
Connector	17
Turning On/Off the Receiver	24
Using Internal and External Power Sources	24
Batteries	25

Inserting and Removing the Battery	26
Charging the Batteries	31
Insufficient Power	34
Viewing Receiver Information	35
Loading New Firmware	37
About the OAF	41
Checking the Receiver's OAF	42
Loading an OAF	43
Performing a Factory Reset (Clearing the NVRAM)	45
POWERUP Script Requirements	47
Installing the POWERUP Script	47
Uninstalling the POWERUP script	48
Editing the POWERUP Script	48
Enabling the POWERUP Script	48
Disabling POWERUP Script	49
Managing the Radio Modem	49
Setting Up the Base Receiver	51

Setting Up the Rover Receiver	52
Measuring Antenna Height	53
Setting Recording Parameters	54
Logging Rates.	54
Using SD/SDHC Cards	55
To install/remove the SD/SDHC card:	56
Recording Data	57
Managing Files.	58
Downloading and Deleting Files	58
Check This First!	59
Powering Problems.	60
Receiver Problems	61
Bluetooth Problems	65
SRU Problems	67
Cleaning and Storing the Receiver.	68
Getting Customer Support	68
General Details	69

GPS Board Details	76
Bluetooth Module Details	78
Internal Digital UHF II Modem General Specifications.	79
Optional Cellular Module Details.	81
CDMA Module Specifications	81
HSPA Module Specifications	82
Battery (BDC70) Specifications	83
Charger (CDC68) Specifications	84
Connector Specifications	85
UHF Radio Modem Connector	85
Power Connector	86
C-RS232 Serial Cable Connector	87
SD/SDHC Card Recommendations.	88
General Warnings	91
Battery Pack Warnings	92
Receiver Warnings	93
Usage Warnings	93

FCC Compliance. 94

Industry Canada Compliance 95

Community of Europe Compliance 96

 European Community Declaration of Conformity with R&TTE Directive 1999/5/EC 96

Declaration of Conformity (R&TTE Directive 1999/5/EC) 99

WEEE Directive 102

Bluetooth Transmission Statements/Compliance 102

Introduction

Sokkia's GRX2 receiver is a compact, lightweight, and completely integrated GNSS receiver for static and kinematic applications. The integrated receiver design includes a 226-channel GNSS receiver board, superior dual frequency antenna, and wireless communication technology. The GRX2 delivers world-class positioning and navigation capability to your application by tracking signals from multi-constellation satellite systems, including GPS, GLONASS, and SBAS.

The GRX2 offers complete IP67 protection against dust and water ingress, in addition to superior vibration and shock resistance. The communication interface allows you to quickly integrate Sokkia's premium GNSS performance within new systems and quickly deliver positioning and navigation support to your applications.



Figure 1: GRX2 Receiver

GRX2 Features

The GRX2 receiver features the following:

- A premier multi-constellation GNSS board
- Superior antenna technology
- Serial (RS-232C) and power ports
- Detachable battery
- A highly visible display panel with single-button operation
- External memory card slot
- Integrated Bluetooth® wireless and radio technology
- Optional HSPA (3.5G)¹ and CDMA Cellular technology
- Voice notifications for important receiver operations
- Integrated and rugged design

The GRX2 comes in one of the following configurations:

- Static (No integrated radio/cellular module)
- Digital UHF II radio modem
- Digital UHF II radio modem with HSPA module
- Digital UHF II radio modem and CDMA module (US only)

1. High-Speed Packet Access (HSPA) cellular module supports faster data rate and is backward compatible with GPRS/EDGE (GSM) technology.

Unpacking Your Receiver Kit

This section describes the documentation, standard kit components, and accessories (depending on your purchase) that accompany your receiver. When you unpack your receiver kit, verify you received the items listed in this section. Make sure the items do not appear damaged from shipment. If any of the items are missing or damaged, contact your Sokkia dealer or Sokkia technical support. See “Getting Technical Support” on page 6.

- Standard components are illustrated in Figure 2.
- Receiver accessories are illustrated in Figure 3.
- Receiver documentation is listed on page 4.

System Components

The items illustrated in Figure 2 are included with your receiver.



Figure 2: Standard System Components

Accessories

Sokkia offers a wide variety of accessories (see Figure 3) specially designed to improve system flexibility and job site efficiency. For more details on the optional accessories available for GRX2, contact your Sokkia dealer.



Figure 3: Receiver Accessories

Technical Documents

The GRX2 Manual CD includes three manuals (listed below) that help you set up and use your new receiver quickly and efficiently.

- *GRX2 Operator's Manual* – An on-screen help document that contains detailed information on how to use your new receiver.

- *GRX2 Quick Start Guide* – An on-screen help guide that contains instructions for quickly setting up your new receiver and begin using it.
- *Sokkia Receiver Utility (SRU) Reference Guide* – An on-screen help document that contains detailed information on how to use the SRU software included on the GPS+ Software CD. For more information about the SRU software, see “Using Sokkia Software With Your Receiver”.

Using Sokkia Software With Your Receiver

Use the GRX2 receiver in conjunction with the Sokkia Receiver Utility (SRU) and MAGNET Field™ applications. Sokkia software enables you to configure the receiver and other external devices, manage files, collect data, and perform survey and construction work flows.

SRU is a hardware configuration software for receivers and peripheral devices. You can install it on desktop computers and data controllers. This program is provided on the SRU Software CD that accompanied your receiver. A SRU help document is provided on the GRX2 CD.

The MAGNET Field™ software for data controllers provides real-time communication, cloud storage, data collection and exchange, and field solutions, such as topo, staking, roads, calculations, and more.

Contact your Sokkia dealer for more information about Sokkia software or the GRX2 receiver system.

Getting Technical Support

Before contacting a Sokkia customer representative about any problems with the receiver, see “Troubleshooting” on page 59 for some solutions that may fix the issue.

Contact your local Sokkia dealer or visit the Sokkia Support site (www.SokkiaSupport.com) for technical support.



For quick and effective support, provide a detailed description of the problem.

When contacting Sokkia for technical assistance, provide the following information for better and faster service:

1. A description of the following:
 - Field operation that was being performed when the problem occurred
 - Details of the unexpected behavior, symptoms, and any error messages that precede or follow the problem
 - Problem occurrence frequency or patterns
2. Receiver information and configuration settings. For receiver information, click **Information** in SRU, select **Save to File**, enter a file name, and save it to the computer.
3. Specifications of mobile devices and computers used in the field or office exhibiting the problem. These specifications should include model information, version number, operating system information, memory and storage capacity, etc.
4. Information about the system software, including the version number and steps to reproduce the problem.
5. A description of the field environment and/or observation conditions when the problem occurred.

Website

The Sokkia website provides current information about Sokkia's line of products. The support area of the website provides access to Sokkia field and office software, manuals, frequently asked questions, and so forth.

To access the Sokkia website, visit www.sokkia.com.

To access the Sokkia support site, visit www.sokkiasupport.com.

Phone

To contact Sokkia Customer Support by phone, call:

- 1-800-4-Sokkia or 1-800-476-5542
- 1-866-4-Topcon or 1-866-486-7266

Getting Acquainted

The GRX2 receiver enclosure is fully sealed and incorporates the GNSS receiver board, antenna, and wireless communication devices. The receiver's enclosure also includes dedicated space for batteries, external memory storage, and a SIM card.

Receiver Overview

The GRX2 receiver's advanced design reduces the number of cables required for operation, allowing for more reliable and efficient file data collection.

An easy-to-operate display panel, mounting socket, battery bay door, connection ports (serial, power, and radio antenna), and labels with receiver information are located on the bottom of the receiver's magnesium alloy lower enclosure.

The GRX2 receiver has a highly-visible display panel with single-button operation. The display panel enables you to view the receiver's operational status. For more information, see "Display Panel Operations" on page 18.

The mounting socket (Figure 4) connects the receiver to either a standard 5/8" thread pole or adapter.

You can locate regulatory and product identification information on the two receiver labels. The product identification label contains the serial number and part number.

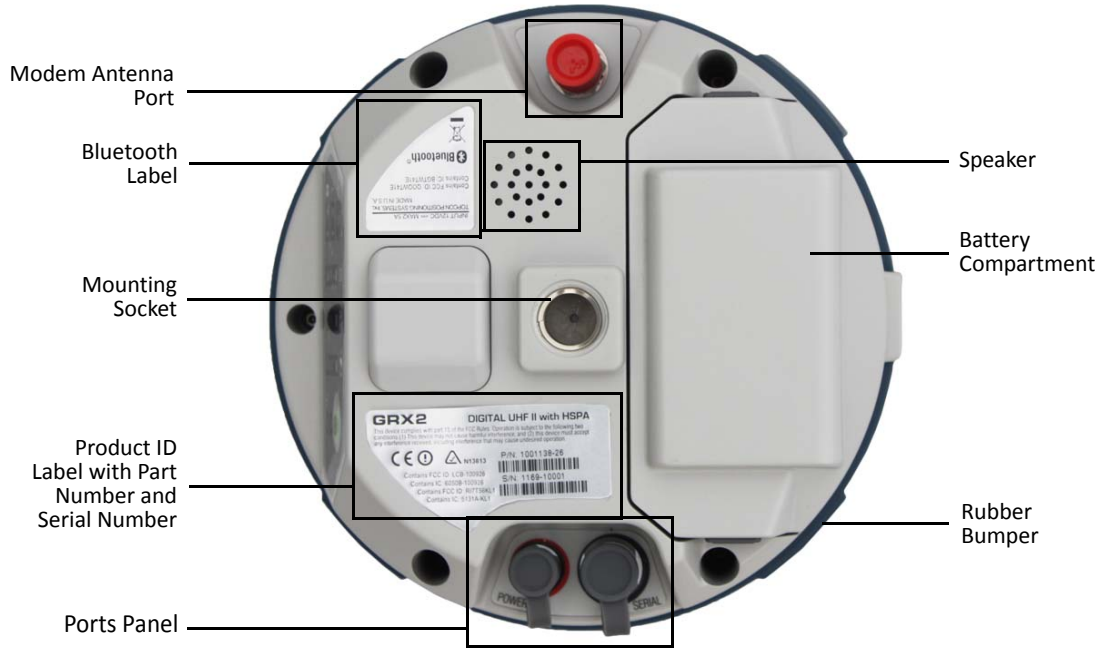

Figure 4: Bottom Enclosure Overview

Cables

The GRX2 package includes a serial cable for configuring the receiver. Table 1 describes the cable included with your receiver and optional cables that are available as accessories.



Align the keyways when connecting the power/serial cable to the receiver port. Turn the cable lock clockwise until it clicks to secure the cable in place. To disconnect the cable, turn the lock counter-clockwise, and then gently remove the cable.

Table 1. Receiver Cables

Cable Description	Cable Illustration
<p>Serial Cable Connects the receiver to an external device (controller or computer) for data transfer and receiver configuration. p/n 72692</p>	

Table 1. Receiver Cables

Cable Description	Cable Illustration
<p>Battery Charger Cable (Optional)</p> <p>Connects the power adapter to the battery charger. Several options are available for the battery charger cable based on your country. If your kit does not include this cable, contact your Sokkia dealer. Refer to these part numbers for available battery charger cables:</p> <p>p/n 73113A – Cable, Power, CDC68 (EUR) p/n 210160124 – Cable, Power, CDC68 (US) p/n 73113C – Cable, Power, CDC68 (AUS) p/n 2212113F0 – Cable, Power, CDC68 (Brazil)</p>	
<p>Power Charger Cable (Available for Purchase)</p> <p>Connects the power adapter to a grounded outlet. Several options are available for the power charger cable based on your country. To purchase this cable, contact your Sokkia dealer. Refer to this part number:</p> <p>p/n 14-008054-01 – Cable, Power Charger (EUR) p/n 14-008052-01 – Cable, Power Charger (US) p/n 14-008074-01 – Cable, Power Charger (AUS) p/n 1000475-01 – Cable, Power Charger, 1.8M (Brazil NMetro)</p>	

Table 1. Receiver Cables

Cable Description	Cable Illustration
<p>Power Adapter (Available for Purchase) Charges the receiver when connected to a grounded outlet and the power charger cable. To purchase this cable, contact your Sokkia dealer. Refer to this part number: p/n 22-034101-01 – Power Supply with SAE Connector</p>	
<p>Receiver Power Cable (Available for Purchase) Connects the receiver to the power adapter through the SAE connector. To purchase this cable, contact your Sokkia dealer. Refer to this part number: p/n: 700355130X</p>	

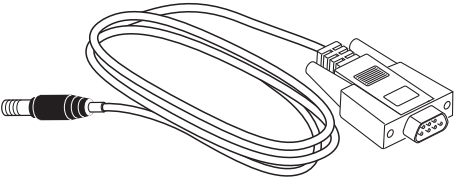
Memory

The GRX2 is equipped with an accessible SD/SDHC card slot for data storage. As data is logged to the SD/SDHC card, the Memory Capacity Bar displays the memory capacity status. See “Memory Capacity Bar” on page 22 for more information. To access the raw data files on the SD/SDHC card, see “Using SD/SDHC Cards” on page 55.

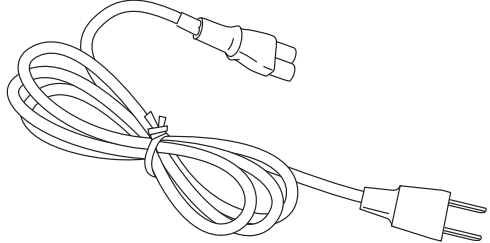
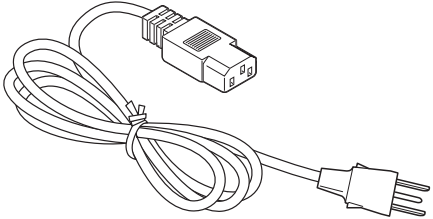
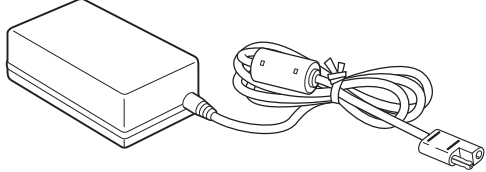
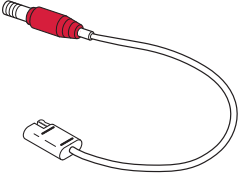
Detachable Batteries

The receiver first draws power from a connected external power source. When there is no valid external power source connected or if the source has discharged lower than 7.2V, the receiver will draw power from a rechargeable high-capacity battery. The GRX2 receiver standard kits include two detachable Li-Ion batteries for powering the receiver and one battery charger. Each battery is capable of running for more than 7.5 hours on a single charge [in static mode with a Bluetooth® connection and at 68° F (20° C)]. See “Batteries” on page 25 for more information.



The batteries are shipped from the factory with a partial charge. For maximum operating time, fully charge the batteries before using the receiver.

Voice Notification

The GRX2 receiver has a voice notification feature that issues a series of voice messages and sounds to alert you to different system status’ and event conditions.



The GRX2 is pre-configured with either voice messages or sounds at a preset volume. To modify volume settings, use the SRU software or other application software.

The frequency of the voice messages or sounds depends on the specific conditions; the frequency is either once (when the condition first occurs) or repeated (every 30 seconds for a set period of time).

The following events generate messages from the GRX2 audible annunciator:

Table 2. Audio Event Index

N	EVENT NAME	DESCRIPTION
1	LOGEPOCH	Message recorded to file
2	STARTUP	System has completed startup
3	SHUTDOWN	Receiver is shutting down (immediate)
4	BTNPOWER	Power Button – Power On
5	BTNFRESET	Power Button – Factory Reset
6	BTNFORMAT	Power Button – SD Format
7	BTNIGNORE	Power Button – Return to normal operation
8	BATTLOW	Battery power is low
9	MEMLOW	Remaining space on SD memory card is low
10	MEMFULL	SD memory card is full
11	RTKFIXED	RTK solution is now Fixed
12	RTKFIXLOST	RTK solution is no longer Fixed
13	CONNECT	Bluetooth has been connected
14	DISCONNECT	Bluetooth has been disconnected

Data and Power Ports

The GRX2 has the two ports described below:

- Serial - rimmed in black; used for communication between the receiver and an external device. The body of the connector on the corresponding cable is black.
- Power - rimmed in red; used to connect the receiver to an external power source. The body of the connector on the corresponding cable is red.

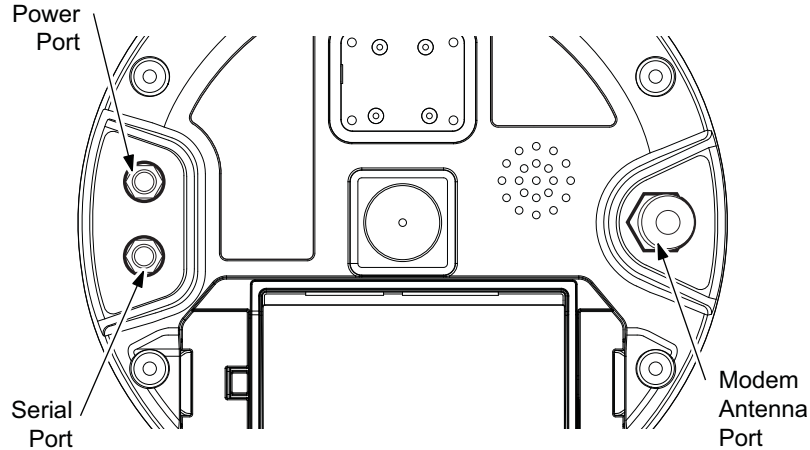

Figure 5: GRX2 Ports

External Radio Antenna Connector

The antennas for the receiver's internal UHF radio (and optional cellular modem) connect to the BNC external antenna connector located under the GRX2 housing (Figure 6).

The optimal modem antenna depends on the frequency of the UHF radio that is installed in the receiver:



Figure 6: UHF Antenna

- UHF: Uses a BNC RF connection and comes in two versions:
 - 410-440Hz (30-070003-01)
 - 440-470Hz (30-050503-01)
- Cellular Antenna: Sold separately (p/n: 1001313-01 ANTENNA, 1/2 WAVE, QUAD BAND W/TNC-To-BNC adapter)

Connector

The bottom connector (Figure 7) enables you to mount the receiver to either a standard 5/8" thread pole or adapter.

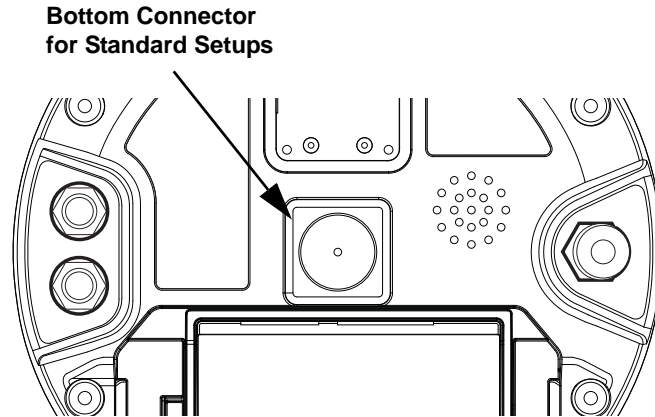

Figure 7: GRX2 Bottom Connector

Display Panel Operations

The GRX2 LED Display Panel is used to display and indicate the receiver's current operational status. The display offers a compact but valuable summary of the most important receiver information for the typical user. This chapter describes the different LED blink patterns and what they mean.

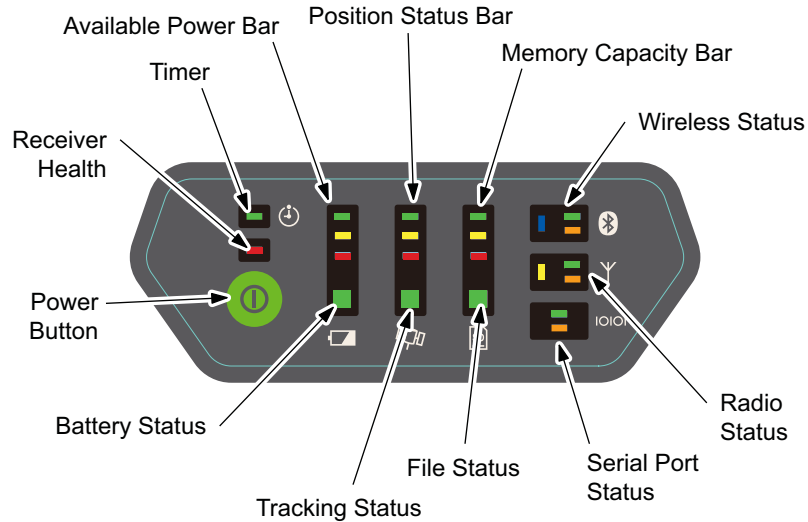



Figure 8: LED Display Panel

The LED display table below describes the meaning of the LED icons used in this section.

LED ICON KEY			
DISPLAY	SOLID	BLINKING	OFF
			

Power Button performs multiple functions. The number of seconds that the power button is pressed and held determines how the receiver will behave. At specific time intervals, the receiver issues voice messages or sounds to guide the user through the available options.



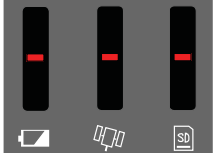
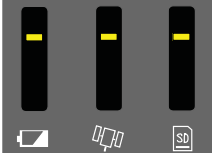
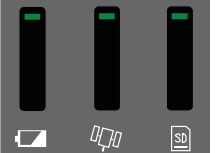

① POWER BUTTON FUNCTIONS		
ACTION	SECONDS	DESCRIPTION
Power ON	Press for 1 second	The GRX2 powers ON.
Power OFF	Press for 3 seconds	The GRX2 powers OFF.
WITH POWER ON		
Factory Reset (Clear NVRAM)	Press for 10 seconds	Resets all parameters on the GRX2 to their default values.
Erase All Files	Press for 20 seconds	Deletes all files from the SD/SDHC card.
Disregard	Press for more than 25 seconds	No action. The GRX2 will return to normal operation.
Open/Close Data File	Within 2 seconds	Start a raw collection to a new file, or close a currently open file.

Boot during the boot process the display indicates boot progress.

Progress	First	Second	Last
Display			



Available Power Bar indicates the remaining battery charge or remaining voltage when using external power.



AVAILABLE POWER BAR		
DISPLAY	INTERNAL POWER REMAINING	EXTERNAL POWER REMAINING
	Greater than 50%	Greater than 8V
	Greater than 25%	Greater than 7.25V
	Greater than 10%	Greater than 6.5V
	Less than 10%	Less than 6.5V





Battery Status LED indicates the currently available power sources for the GRX2.



BATTERY STATUS	
	Only the internal battery is available.
	Only external power is available.
	Both the battery and external power are available.





Position Status Bar indicates the current type of position computed.









POSITIONING STATUS BAR	
	RTK fixed solution.
	DGPS or RTK float solution.
	Stand-alone or base mode.
	Invalid or no position.

Tracking Status LED indicates the number and type of satellites currently being tracked by the GRX2.





TRACKING STATUS		
ORDER	DISPLAY	STATUS
1		Blink per tracked GPS satellite.
2		Blink if no satellite signal with SNR value >48 dB*Hz.
3		Blink per tracked GLONASS satellite.
4		Blinks once when no satellites or no solution. Off otherwise.



Memory Capacity Bar indicates the percentage of available space on the SD/SDHC memory card.







MEMORY CAPACITY BAR	
	Greater than 50%
	Less than 50%
	Less than 25%
	Less than 10%
	Memory full or SD/SDHC card is not ready.
	No card is installed.

File Status LED indicates the status of the current file.

FILE STATUS	
	A file is open.
	Writing to the file.
	A file is not open or there is no SD/SDHC card in the slot.



Communication Status LEDs

-  Wireless Status LEDs indicate the status of the internal Bluetooth module
-  Radio Status LEDs indicate the status of the internal UHF radio and HSPA/CDMA module.
-  Serial Port Status LEDs indicate the status of serial port.

COMMUNICATION STATUS (WIRELESS/RADIO/SERIAL PORT)	
	Bluetooth connection is established.
	Waiting for Bluetooth connection.
	Bluetooth module is not powered.
	Internal radio is powered.
	Internal radio is not powered.
	Data is being transmitted from the associated port.
	Data is being received by the associated port.

Timer LED is used in job programming to indicate various states of a job.



TIMER STATUS	
	A Timer JOB has started and is waiting to begin file operations.
	The file is opened by the JOB.
	The file is closed by the JOB or no JOB was activated/executed.

When the GRX2 is powered off and a timer JOB is in waiting, the timer LED blinks once every two seconds momentarily.



After a job has been activated, is waiting for execution, or is being executed, you cannot power off the receiver using the Power button.

Managing Power



This chapter describes how to power the receiver, charge the detachable batteries, and use an external power source.

Turning On/Off the Receiver

To turn on the receiver, press and hold the power button until the LEDs briefly flash. When the receiver is turned on, the receiver's channels initialize and begin tracking all visible satellites at any time and location.

To turn off the receiver, press and hold the power button for more than three and less than 10 seconds (release the power button when the BATT LED blinks solid red). This delay prevents the receiver from being turned off by mistake.



The receiver will draw a small amount of power from the batteries when it is turned off. If the receiver is placed in storage for a long period, such as a few months, the batteries may become fully discharged. You will need to use an external power supply or recharge the batteries before use.

Using Internal and External Power Sources

The receiver is powered by the detachable batteries or an external power source connected to the power port. If an external power source is connected, the receiver draws power from it over the battery.

You can connect the receiver to an external power source, such as a vehicle battery, with 6.7 to 18 VDC to operate the receiver. See “Specifications” on page 69 for more information on external power source requirements to power the receiver and charge the internal batteries.



Power input greater than 18 VDC could damage the receiver.

Batteries

The battery compartment door provides access to the main battery. The receiver can also be powered using an external power source.

Use one BDC70 rechargeable battery at a time to power the receiver.

The GRX2 also contains an internal backup battery, which maintains an internal RTC. The backup battery is automatically charged from the main battery.

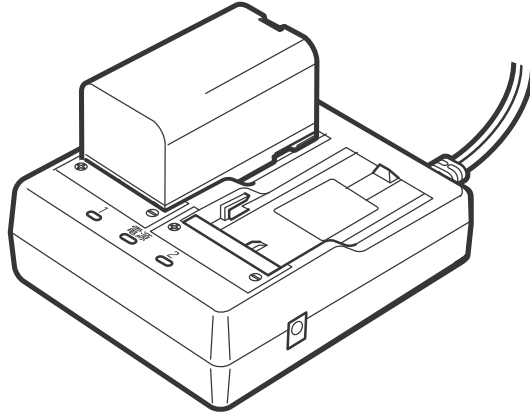

Figure 9: GRX2 Battery and Charger

Inserting and Removing the Battery

- First, before removing the battery, always turn off power to the receiver. If the battery is removed while the power is switched on, uncontrolled system shutdown will occur and file data may be lost as a result.
- When inserting or removing the battery, make sure that moisture, dust, or other foreign particles do not come in contact with the inside of the instrument.
- Remove batteries from the surveying instrument or charger before placing into storage.

- Store the battery in a dry room where the temperature is within the following ranges. For long-term storage, the battery should be charged at least once every six months.

Table 3. Battery Storage Time

Storage Period	Temperature
1 week or less	-20°C to +50°C
1 week to 1 month	-20°C to +45°C
1 month to 6 months	-20°C to +40°C
6 months to 1 year	-20°C to +35°C

- The BDC70 uses the latest advances in high density lithium-ion battery technology; however, like all batteries, it still generates power using a chemical reaction and as a result, has a limited lifetime. Even when the battery is in storage and not used for long periods, the battery capacity deteriorates with the passage of time. This may result in the operating time of the battery shortening despite having been charged correctly. In this event, a new battery is required.

To Remove the Battery:

1. Turn over the GRX2.

2. Push the buttons on both sides of the battery compartment cover, and lift the battery cover.

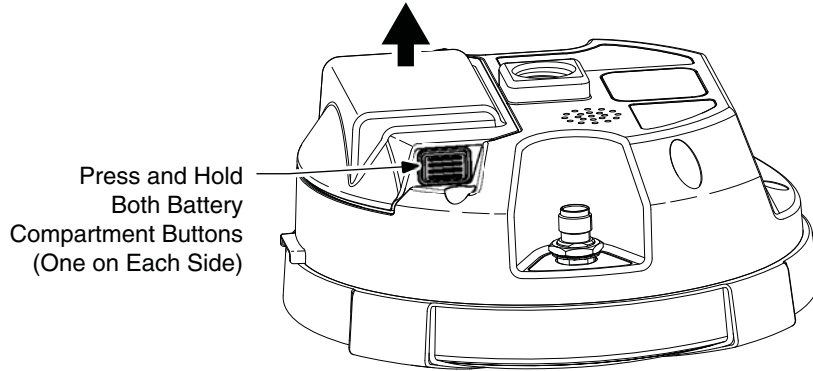

Figure 10: Remove Battery Compartment Cover

- Slide the battery to the right, and separate the battery from the connector.

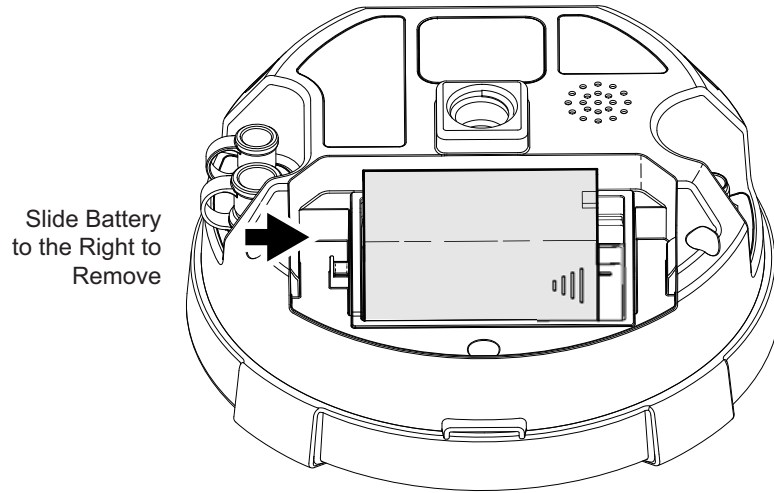

Figure 11: Remove Battery

- Lift up the battery, and remove it from the receiver.



Only use a GRX2 battery with this receiver. Using an incorrect battery type may cause the battery to explode and damage the receiver.

To insert the battery:

1. Remove the battery cover.
2. Gently slide the bottom of the battery along the battery guides until it snaps into place (Figure 12 on page 4-30).

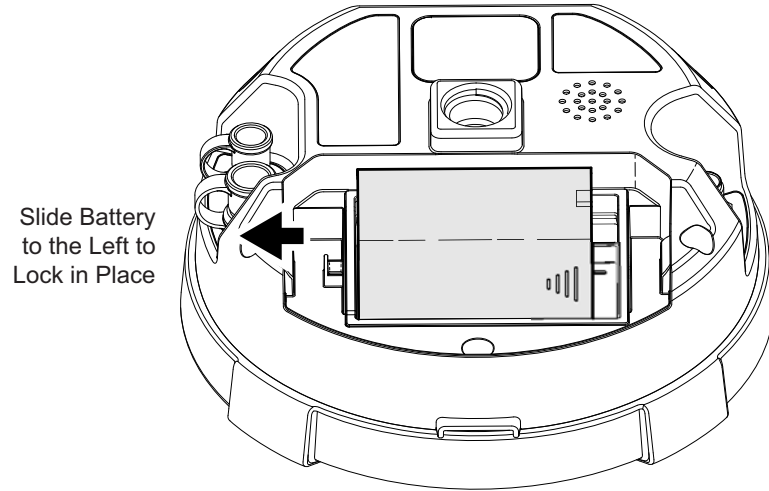
**Figure 12: Remove Battery Compartment Cover**

Charging the Batteries

When the battery charge is low, the Available Power Bar changes from solid green to yellow to red and then blinking red, depending on the remaining charge (see “Available Power Bar” on page 20). When the receiver is connected to an external power source, the battery does not charge and becomes disabled from supplying power to the receiver.

To charge the battery, use the supplied charger. It takes approximately 4 hours to completely charge one battery and 8 hours to completely charge two batteries. The Li-Ion batteries used in the battery packs should run at no less than 80% capacity after 500 charging cycles. You do not need to drain the batteries before recharging.



The batteries are shipped from the factory with a partial charge. For maximum operating time, fully charge the batteries before using the receiver.

To charge the batteries:

1. Connect the power cable to the charger and plug the charger into the wall outlet.

2. Mount the battery in the charger by matching the grooves on the battery with the guides on the charger.

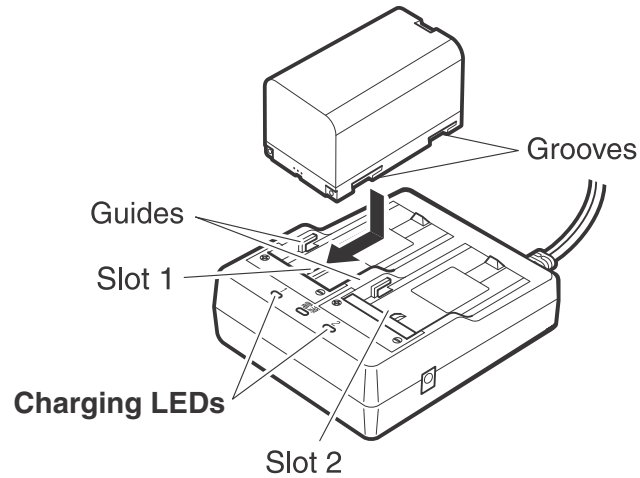

Figure 13: Insert Battery onto Charger

3. When charging begins, the lamp light blinks.
4. The lamp light is solid when charging is complete.

5. Remove the battery and unplug the charger.

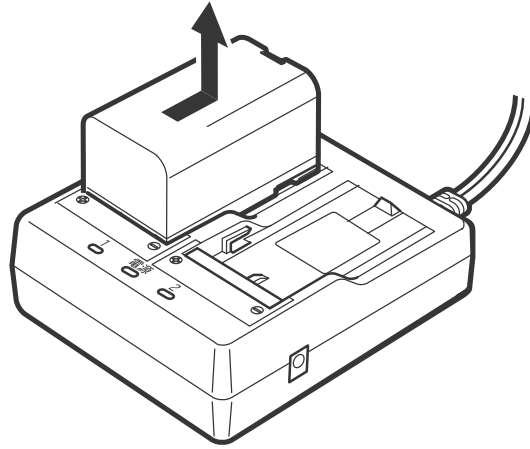

Figure 14: Remove Battery



Slots 1 and 2: The charger starts charging the battery mounted first. If two batteries are placed in the charger, the battery in slot 1 is charged first, and then the battery in slot 2.



Charging lamp: The charging lamp is off when the charger is outside the charging temperature range or when the battery is mounted incorrectly. If the lamp is still off after the charger falls within its charging temperature range and the battery is mounted again, contact a local dealer.



Charging time per battery (at 25°C) is about 4 hours (Charging can take longer when temperatures are either especially high or low.)

Insufficient Power

If the batteries become fully discharged and an external power supply is not connected, the receiver will shut down and automatically save recorded files. To avoid disruptions, check the Available Power Bar on the display panel for the battery charge status. See “Available Power Bar” on page 20 for more information.

If the receiver shuts down due to insufficient power, the receiver and all communication ports become de-activated.

To restore power to your receiver and turn it back on, do one or all of the following:

- Recharge the batteries.
- Make sure the power/serial cable is securely connected to the receiver’s port. Align the keyways (indicated with a red dot) when connecting the power/serial cable to the receiver port.
- Connect the receiver to a different power source.



Power supplied to the receiver should match the specifications provided by Sokkia on the product. Failure to comply with these specifications may damage the receiver.

Configuring the Receiver



Viewing Receiver Information

The section describes receiver options, and how to load a new Option Authorization File (OAF), update firmware, and perform a factory reset. To do this, you will need to use the Sokkia Receiver Utility (SRU) software that was supplied on the SRU CD. For information about installing the software, see the *Sokkia Receiver Utility (SRU) Reference Manual*.

In the Sokkia Receiver Utility (SRU), the **Receiver Info** window displays basic receiver information, such as hardware and firmware versions, RAM size, receiver ID, serial number, etc.

To open the Receiver Info window:

1. Connect the receiver to a computer and open SRU.
2. In SRU, connect to the receiver.
3. Click **Device ▶ Application Mode ▶ Receiver Managing**.
4. Click **Device ▶ Connect**.
5. In the **Connection Parameters** window, select the correct serial port, and click **Connect**.
6. In the SRU main window, click the **Information** icon. The **Receiver Info** window (Figure 15) appears.

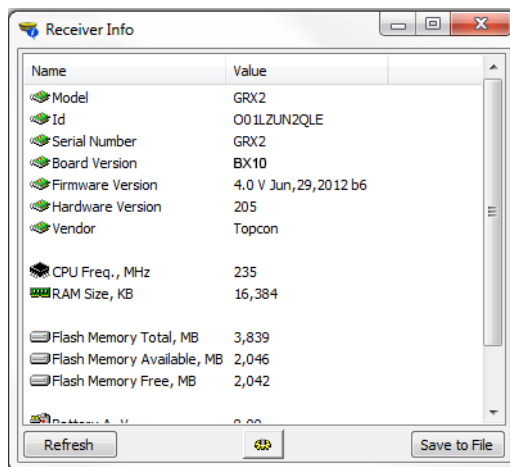

The screenshot shows a window titled "Receiver Info" with a table of system parameters. The table has two columns: "Name" and "Value". The parameters listed include Model, Id, Serial Number, Board Version, Firmware Version, Hardware Version, Vendor, CPU Freq., RAM Size, Flash Memory Total, Flash Memory Available, and Flash Memory Free. At the bottom of the window, there are buttons for "Refresh" and "Save to File".

Name	Value
Model	GRX2
Id	O01LZUN2QLE
Serial Number	GRX2
Board Version	BX10
Firmware Version	4.0 V Jun,29,2012 b6
Hardware Version	205
Vendor	Topcon
CPU Freq., MHz	235
RAM Size, KB	16,384
Flash Memory Total, MB	3,839
Flash Memory Available, MB	2,046
Flash Memory Free, MB	2,042

Figure 15: SRU – Receiver Info

Loading New Firmware

Receiver board firmware is released as a compressed file that you download and decompress. This file contains the following two files:

- Main board firmware
- GNSS firmware
- Radio firmware

To upload GNSS and radio firmware files to the receiver:

1. Connect the receiver to a computer using the serial cable.
2. To connect to the receiver in SRU:
 - a. Click **Device ▶ Application Mode ▶ Receiver Managing**.
 - b. Click **Device ▶ Connect**.
 - c. In the **Connection Parameters** window (Figure 16), select **Serial Port** and the port name, and then click **Connect**.

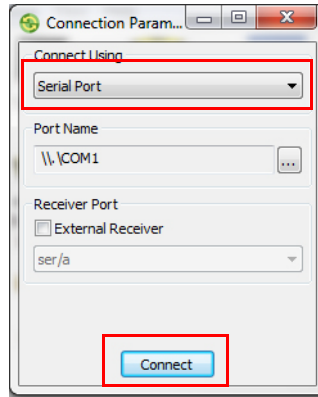



Figure 16: Connection Parameters Window

3. Click the **Firmware**  icon in the SRU main window. The **Upload Firmware** window (Figure 17) displays. This window enables you to upload firmware files to the connected receiver.
4. Make sure **Receiver** is selected in the **Device** field.
5. (Recommended) Select **Soft Break** as the **Capture Method**.
6. Browse for and select the receiver board's RAM and Flash files (Figure 17).

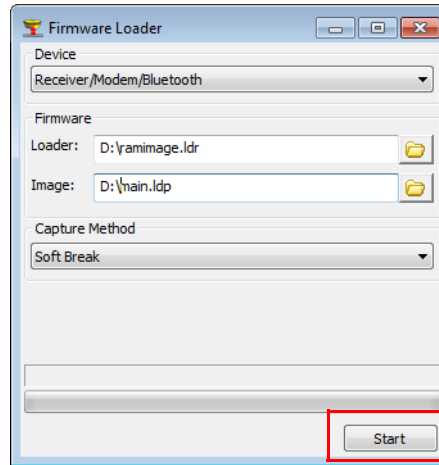

Figure 17: Upload Firmware Window

7. Click **Start** to upload the selected files.
8. Click **OK** to continue uploading new firmware to the receiver (see Figure 18).

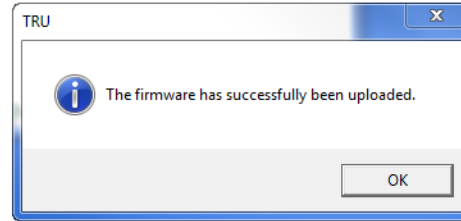
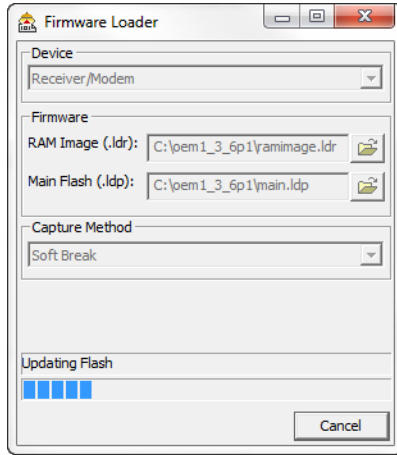

Figure 18: Finishing Firmware Upload

To load the main board firmware file to the receiver:

1. Perform a factory reset on the receiver. See “Performing a Factory Reset (Clearing the NVRAM)” on page 45.
2. Remove the storage card from the receiver. See “To install/remove the SD/SDHC card:” on page 56.
3. On the storage card, create a “Firmware” folder, and copy the **acpu.sbc** file into the folder.
4. Insert the storage card back into the receiver.
5. Power on the receiver. The receiver will power up 20 to 30 seconds slower than normal. The |0|0| LED begins to flash, indicating the firmware is uploading.

6. Reset the receiver again to return it to its original factory settings.
7. Use the Sokkia Receiver Utility (SRU) to ensure the firmware was uploaded successfully. See “Loading New Firmware” on page 37.

About the OAF

Sokkia issues an Option Authorization File (OAF) to enable the specific options that you purchased. Sokkia’s OAF system allows you to customize and configure the receiver according to your particular needs, therefore purchasing only the options you require.

The GRX2 receiver typically ships with an OAF as per initial purchase of the receiver kit configuration. There are several upgrade options available with the receiver that can extend the receiver’s functionality to better suit your job requirement. Examples of upgrade options are listed below:

- GPS + GLONASS dual frequency static operation
- Radio-based RTK operation
- Network RTK operation
- RTK and update rate up to 20 Hz (10 Hz standard)

Contact your Sokkia dealer or a representative for a complete listing of available options and pricing information.

Checking the Receiver's OAF

To use SRU to view the status of the receiver's options:

1. Connect the receiver to a computer and open SRU. See the *Sokkia Receiver Utility (SRU) Reference Manual* for more information about connecting the receiver to a computer.
2. In SRU, connect to the receiver.
3. Click the **Options**  icon in the main window. The **Receiver Options** window (Figure 19) displays, so you can view the current authorization options and upload new ones.

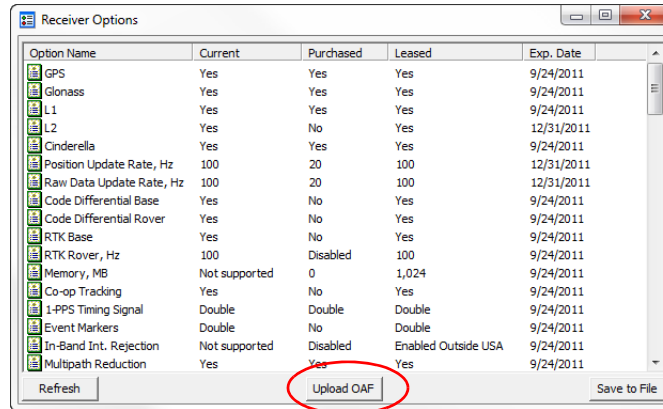

Figure 19: Receiver Options

Loading an OAF

Sokkia dealers provide customers with OAF files. For any OAF related questions, e-mail Sokkia at options@Sokkia.com and include the receiver's ID and serial number. To obtain these numbers, see "Viewing Receiver Information" on page 35.

To load a new OAF:

1. Follow the steps in "Checking the Receiver's OAF" on page 42.
2. Click **Upload OAF** on the bottom of the **Receiver Options** window (see Figure 19).
3. Navigate to the location of the new Option Authorization File (Figure 20).

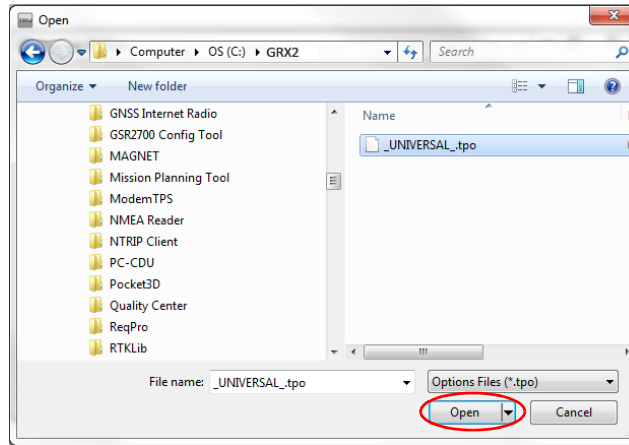

Figure 20: Load OAF

- Select the appropriate file, and click **Open** (Figure 20).
Sokkia's SRU initially checks to see if the selected file is compatible with the currently connected receiver. If you chose a file not intended for this receiver, the **Upload OAF** window displays an error icon next to the Receiver ID and disables the **Upload the File to the Receiver** button.

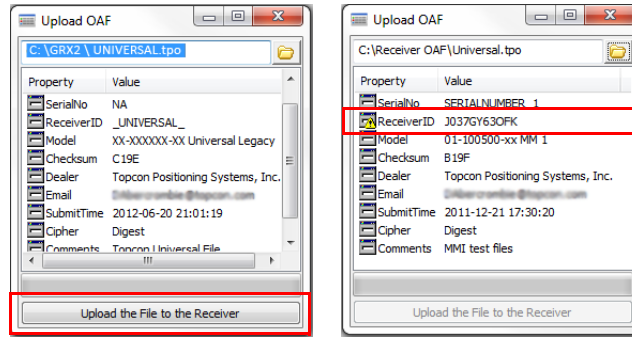

Figure 21: OAF Compatibility Check

5. Press **Upload the File to the Receiver** (Figure 21) to start loading the file. If an OAF file is uploaded to the receiver, SRU will offer to reset the receiver to put new authorization options into operation (Figure 22).

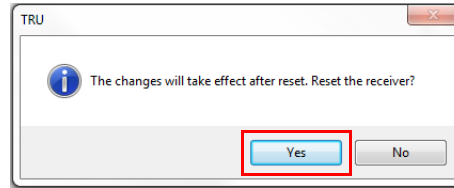

Figure 22: Reset the Receiver

6. Click **Yes**.

Performing a Factory Reset (Clearing the NVRAM)

The receiver's Non-Volatile Random Access Memory (NVRAM) holds data required for satellite tracking, such as ephemeris data and receiver position. The NVRAM also keeps the current receiver's settings, such as active antenna input, elevation masks and recording interval, and information about the receiver's internal file system. Clearing the receiver's NVRAM restores the receiver's factory default settings.

Although clearing the NVRAM is not recommended as a common practice, there are times when it can eliminate communication or tracking problems.

After clearing the NVRAM, the receiver requires time to collect new ephemerides and almanacs (around 15 minutes).

Clearing the NVRAM will not delete any files already recorded in the receiver's memory, and the NVRAM keeps information about the receiver file system.

You can also use SRU to clear the NVRAM:

1. Connect the receiver to a computer, and open SRU. See the *Sokkia Receiver Utility (SRU) Reference Manual* for more information about connecting the receiver to a computer.
2. In SRU, connect to the receiver.
3. Click the **Tools** icon  in the main window.

The **Tools** window appears, enabling you to reset the receiver and clear the NVRAM.

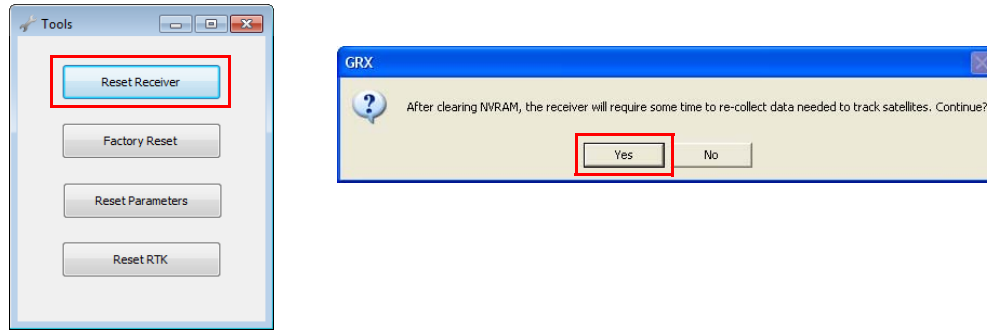

Figure 23: Tools Dialog Box

4. Click **Reset Receiver**, and click **Yes** to continue.

POWERUP Script Requirements

After turning on the receiver, the POWERUP script executes when the receiver obtains valid position coordinates and the following requirements are satisfied.

- The POWERUP script has been installed to receiver.
- The POWERUP script function setting is ON.
- The receiver is not starting by using the timer.
- There is no enabled job/session.

Installing the POWERUP Script

To install the POWERUP script onto the GRX2 receiver:

1. Copy the POWERUP script file “**powerup.gcs**” to the “POWERUP” folder on the SD card.
2. Insert the SD card into GRX2 receiver.
3. Perform a Factory Reset on the GRX2.
4. Once the installation is successful, the “**powerup.gcs**” file is removed from the SD card.



If the file attribution is Read only, the file will not be removed.
If there is the existing POWERUP script on the GRX2, it will be overwritten by the new script file.

Uninstalling the POWERUP script

The POWERUP script can be uninstalled by using either of the following two methods.

Method 1: Install an empty (no script) “powerup.gcs” file.

Method 2: Send the command “set,/ext/powerup/clear,y” using the Terminal feature of SRU.

Editing the POWERUP Script

It is not possible to edit the existing POWERUP script in receiver directly. Install (overwrite) the new POWERUP script after modifying the script using SRU.

Enabling the POWERUP Script

It is necessary to enable the POWERUP script function in order to allow the HiPer II to execute the POWERUP script at every startup of the receiver. Enable the POWERUP script by using any of the following three methods.

Method 1: Send the terminal command “set,/ext/powerup/mode,on”

Method 2: Perform a Factory Reset of the receiver.

Method 3: Enable using the SRU software.

Disabling POWERUP Script

Disable the POWERUP script by using either of the following two methods.

Method 1: Send the terminal command “set,/ext/powerup/mode,off”

Method 2: Disable by using the SRU software.

Managing the Radio Modem

The Sokkia Receiver Utility (SRU) software supports the configuration of all radio modems that are embedded in Sokkia receivers.

To configure the radio modem, have the following ready:

- A computer running a Windows 2000 operating system or newer
- SRU installed on the computer
- A serial cable or Bluetooth-capable computer

For instructions on configuring radio modems, see the *SRU Reference Manual*. Both are supplied on the GRX2 Manual CD and sokkia.com.

Field System Setup

This chapter describes the field setup of your new GRX2, so it is ready for use as a Base, RTK or network Rover, or static data collection.



Figure 24: Equipment and Setup

Setting Up the Base Receiver

1. Mount the receiver on a tripod with a tribrach, tribrach adapter, and prism spacer, as shown in the picture on the right.
2. Position the base system (from step 1) over a known point.
3. Level the tripod and measure the height of the receiver from the ground using the tape measure. See “Measuring Antenna Height” on page 53.
4. Connect the external radio antenna to the antenna port for RTK setup.
5. Press the power button to turn on the receiver. The integrated wireless device in the receiver turns on when the receiver is powered.
6. Connect the receiver to the Bluetooth-enabled data collector, running Topcon Field software, to configure and start the base GRX2 receiver.
7. View the LED display panel for the receiver’s current status. See also “Display Panel Operations” on page 18.



Setting Up the Rover Receiver

1. Mount the receiver on the rover pole, as shown in the picture on the right.
2. Attach a Sokkia controller to the pole using a mounting bracket.
3. If you are not using a fixed height rover pole, measure the height of the receiver from the ground. See “Measuring Antenna Height” on page 53.
4. Connect the external radio antenna to the antenna port for RTK setup.
5. Press the power button to turn on the receiver. The integrated wireless device in the receiver turns on when the receiver is powered.
6. Connect the receiver to the Bluetooth-enabled data collector, running Sokkia Field software, to configure the GRX2 as a rover receiver.
7. View the LED display panel for the receiver’s current status. See also “Display Panel Operations” on page 18.



Measuring Antenna Height

The receiver calculates the coordinates of the antenna's phase center. To determine the coordinates of the station marker, specify the following:

- Measured height of the antenna above the station marker
- Method of measuring the antenna height
- Model of the antenna/receiver used

Any necessary antenna phase center adjustments, based on the antenna model, is automatically applied. This adjustment, when combined with accurately measured height and measurement methods, allows for correctly computed reference marker coordinates.

To accurately measure the antenna height:

1. Measure the antenna height above the control point or marker, either the slant height or the vertical height. You may either measure the vertical height to the Antenna Reference Point (ARP) located at the bottom of the receiver at the base of the mounting threads, or measure the slant height to the Slant Height Measurement Mark (SHMM) on the side of the receiver, as shown on the right.
2. Record the antenna height, points name, and start time in the field notes.

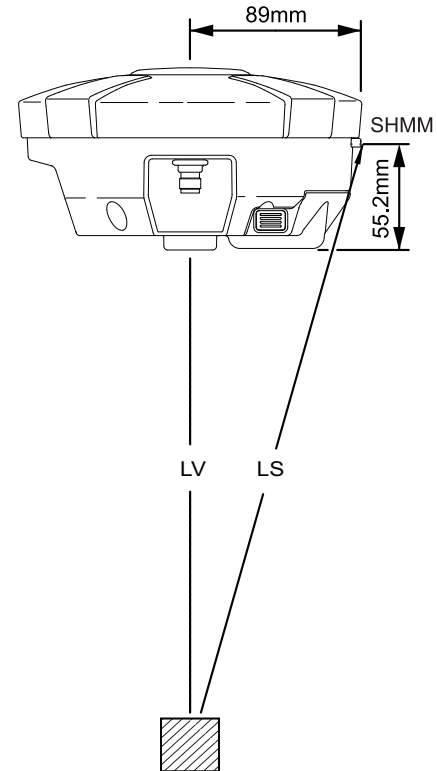

Collecting Data

This chapter provides general information about recording data, downloading it, and managing files.

Setting Recording Parameters

The Sokkia Receiver Utility (SRU) software enables you to set logging parameters, such as logging rate and types of messages, in which to record data. This software and the *SRU Reference Manual* is supplied on the GRX2 CD. See the *SRU Reference Manual* for more information. The GRX2 receiver is compatible with any Sokkia field software for configuration and recording raw data.

Logging Rates

The receiver logs data on the SD/SDHC card that is inserted into the memory card slot. The amount of file space depends on the size of the memory card being used. The GRX2 receiver can support memory cards of up to 32 GB capacity¹. The amount of memory used to log data depends on the logging rate. For more information about setting logging rate parameters, see the *SRU Reference Manual*.

1. The maximum number of files is limited to 512. The receiver may take up to 50 seconds to check larger (8/16/32GB) SDHC cards when inserted into the receiver. For 2 and 4 GB SD/SDHC cards, this external card check is completed instantly, allowing you to use it without any delay.

Using SD/SDHC Cards

The **SD/SDHC card slots** reside under the battery on the inside edge of the battery recess. The data that resides on the SD/SDHC card can be accessed by removing the card and using an external SD/SDHC card reader or by using Sokkia software to download the data from the card via GRX2's serial port or Bluetooth connection. A secure digital card suitable for industrial use can be purchased from a local Sokkia dealer. The SD/SDHC card is available in FAT16 or FAT32 format so that the removable SD/SDHC card is suitable for copying data files directly to a computer. For recommendations about SD/SDHC cards, see "SD/SDHC Card Recommendations" on page 88.

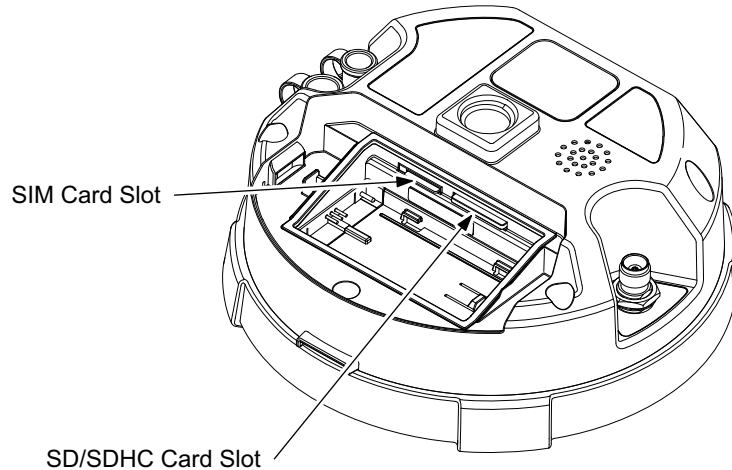

Figure 25: GRX2 Card Slot Example

To install/remove the SD/SDHC card:

1. Ensure the receiver is turned off.
2. Remove the battery. See “Inserting and Removing the Battery” on page 26.
3. Carefully push the SD/SDHC card, label side down, into the SD/SDHC card slot (Figure 25) until it locks into place. Or, push the card once to remove it.

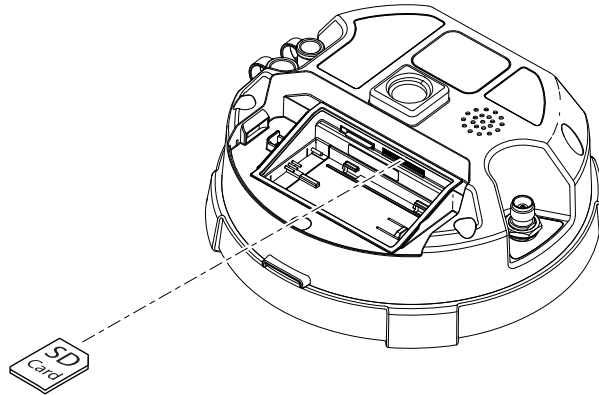

Figure 26: Install SD/SDHC Card



Do not remove the card if the receiver is powered on. Damage to data may result from improper removal of the card.

Once the receiver is turned on, the receiver board will detect the SD/SDHC card, and it will be ready to use as needed.

Recording Data

You can log raw GNSS data to the receiver's memory card and use the Sokkia Receiver Utility (SRU) or MAGNET Office™ software to download the files to a computer.

To start or stop recording data to the receiver, you can use the LED display panel or SRU.

1. Press the Power button to turn on the receiver.
2. Wait for the STAT LED to indicate satellites are being tracked. The STAT LED blinks green for GPS satellites and amber for GLONASS satellites. A short red blink indicates the receiver has not solved a position. Five or more satellites provide optimal positioning.
3. Press the POWER button three times within two seconds to begin recording. You can also select **File Explorer ▶ Logs ▶ Start** in SRU to begin recording data.
4. Make sure the REC light is blinking green. This indicates that a file has opened and data collection has started. The REC LED blinks each time data is saved to memory.
5. When you have finished recording, press the POWER button three times, and make sure the REC LED is dark. You can also select **File Explorer ▶ Logs ▶ Stop** in SRU to end data recording.
6. To turn off the receiver, press and hold the POWER button for 3 to 10 seconds until all LEDs turn dark and the BAT LED is solid red.



You can also log data using MAGNET Field software.

Managing Files

Raw data is recorded as time-tagged measurements in a single raw data file. Each file is recorded to the receiver's memory and automatically given a name and a *.tps file extension. You can then transfer a file of collected data to a computer with file managing software, such as the Sokkia Receiver Utility (SRU), which is supplied on the GPS+ Software CD. This program allows you to use an automatic naming feature, enter file names, and delete files as necessary. For more information, see the *SRU Reference Manual* supplied on the GRX2 CD.

Downloading and Deleting Files

After completing a survey, download data files to a computer or a controller for storage, post-processing, or backup. Downloading and deleting files prepares the memory card for the next survey. (When the memory card is full, the receiver stops logging data, and the REC LED turns dark/off, indicating an error condition. Existing data is not overwritten.)

There are three options for deleting raw data files from the receiver:

- Delete all of the files using the LED display panel (i.e. hold the power button for 20 to 25 seconds). **This erases all of the files in the receivers internal memory.**
- Use a serial or Bluetooth connection to download the files to a computer/controller. In the Sokkia Receiver Utility (SRU), you can select the files you want to delete from the receiver. See the *SRU Reference Manual* for more information.
- Remove the memory card and insert it into the memory card slot of a computer/controller.

Troubleshooting

This chapter will help you diagnose and solve some common problems that may occur with the receiver.



Do not attempt to repair equipment yourself. Doing so will void the warranty and may damage the hardware.

Check This First!

Before contacting your local dealer or Sokkia Support, check the following:

- Check all external receiver connections carefully to ensure correct and secure connections. Double check for worn or defective cables.
- Check the receiver's batteries for a full charge.
- Check the power source for incorrectly connected cables, and ensure the power source is valid. See "Specifications" on page 57 for external power requirements.
- Check the software. Make sure the most current software version is downloaded onto the computer and the most current firmware is loaded into the receiver. Check the Sokkia website for the latest updates.
- Check Sokkia Technical Support (www.Sokkiasupport.com) or Sokkia.com for the latest updates.

Then, try the following:

- Power on and off the receiver by pressing the Power button or by using SRU (**Tools ▶ Reset receiver**).

- Restore default settings by pressing the Power button for 10 to 15 seconds or using SRU (**Tools ▶ Clear NVRAM**). This restores the receiver's parameters to the factory default settings and erases the almanac and ephemeris files. This action does not delete data files from the receiver memory.
- Erase all files by pressing the Power button for 20 to 25 seconds or by using **File Explorer ▶ Delete All Files** in SRU. This will delete all files stored in the receiver's non-removable memory card.

If the problem persists, see the following sections for other solutions.

Powering Problems

The following are some of the most commonly encountered power problems.

The receiver does not power up

- The battery may be discharged.
 - Charge the battery overnight. See “Charging the Batteries” on page 22.
- If you are using an external power source, the cable may be disconnected or damaged.
 - Make sure the cable is securely connected and undamaged.
- The receiver may have a defective charger or defective battery.
 - If, after changing the battery or connecting an external power source, the receiver still does not power up, contact your local dealer or Sokkia Support for advice.

Receiver Problems

The following are some of the most commonly encountered receiver problems.

The receiver cannot establish a connection to a computer or external controller

Cable specific problems:

- The cable is not properly plugged in.
 - Unplug the cable, then securely and properly reconnect it to the receiver.
- The cable is damaged.
 - Use an undamaged cable. Contact a dealer to replace the cable.

Generic problems:

- The receiver port used for connection is not in Command mode.
 - a. Connect the receiver to a computer and open SRU (see “Connection” in the *Sokkia Receiver Utility (SRU) Reference Manual*).
 - b. Click **Receiver Settings ▶ Ports**.
 - c. Change the **Input Mode** for the port used for connection to **cmd**.

The receiver does not lock on to satellites for a long period of time

- The corresponding receiver options may be disabled or expired (L1/L2, GPS/GLONASS must be on to track satellites).
 - Order a new OAF with the desired options activated to enable or extend validity of the corresponding receiver options. Contact a dealer or visit the Sokkia Support website (www.SokkiaSupport.com) for details.

- Refer to the “Receiver Managing” chapter of the *Sokkia Receiver Utility (SRU) Reference Manual* for a detailed description of options.

The receiver tracks too few satellites

- The survey is conducted near obstructions (tree canopy, tall buildings, and so forth).
 - Make sure the Multipath Reduction boxes have been enabled.
 - a. Connect the receiver to a computer and open SRU [see “Connection” in the *Sokkia Receiver Utility (SRU) Reference Manual*].
 - b. In SRU, connect to the receiver.
 - c. On the SRU main window, choose **Receiver Settings ▶ Tracking ▶ Adv** tab. Make sure the **C/A code multipath reduction** check box is selected.
- Move to an area free of obstructions, if applicable.

The receiver cannot obtain Code Differential and/or RTK solutions

- Incorrect Base coordinates entered.
 - Specify the correct coordinates for the Base station using SRU or another suitable field data collection software.
- The corresponding receiver options may be disabled or expired.
 - Order a new OAF with the required options activated to enable or extend validity of the corresponding receiver options.
 - Refer to the *Sokkia Receiver Utility (SRU) Reference Manual* for a detailed description of options.
- There are not enough common satellites. In order to obtain a fixed solution, the Base and Rover should track at least five common satellites.

- Check the elevation masks of the Rover and Base receivers; they should be the same. To do this, on the SRU main window, choose **Receiver Settings ▶ Tracking ▶ Obs.**
- Verify there is a clear view of the sky to allow sufficient satellite tracking.
- A discrepancy exists between the differential standards used at the Base and Rover receivers.
 - Ensure the Base and Rover receivers use the same corrections input/output format:
 - a. Connect the receiver to a computer and open SRU [see “Connection” in the *Sokkia Receiver Utility (SRU) Reference Manual*].
 - b. In SRU, connect to the receiver.
 - c. On the SRU main window, choose **Receiver Settings ▶ Ports.**
 - d. Double-click on the port to be configured and make sure the input mode of the Rover matches the format of the Base output mode (i.e. RTCM3).
- Poor satellite geometry (PDOP/GDOP values are too high).
 - Ensure the elevation mask is less than 15 degrees.
 - Increase the PDOP threshold. To do this, on the SRU main window, choose **Receiver Settings ▶ Tracking ▶ Obs.**
 - Conduct the survey during a time period when satellite visibility and geometry is better (if possible).
- The modem battery is low.
- The specified baud rate is incompatible with the baud rates the modem supports. The baud rate is the rate at which the receiver transmits differential messages to the modem and vice versa.
 - Change the modem’s baud rate.
- The Base and Rover modems use different radio link parameters.
 - Configure the Base and Rover radio modems according to the procedures listed in the *SRU Reference Manual*.
- The distance between the Base and Rover is too far.
 - Close the distance between the Base and Rover.

- Use repeaters to increase radio coverage.
- The elevation mask is above 15 degrees.
 - Lower the elevation mask. To do this, on the SRU main window, choose **Receiver Settings ▶ Tracking ▶ Obs.**
 - Verify there is a clear view of the sky to allow sufficient satellite tracking.
- There may be a source of radio interference that disrupts radio communications.
 - Change the RF channel (if possible).
 - Removing the source of the jamming signal or relocate the radio antennas (if possible).

The receiver does not start logging data

- The SD/SDHC card is not properly inserted.
- The receiver memory option is disabled or expired.
 - Make sure the memory option is enabled. For details, see the *Sokkia Receiver Utility (SRU) Reference Manual*.
- The receiver's memory card does not have free space.
 - Download and/or delete data files to free up space for new files. See "Downloading and Deleting Files" on page 46.
 - The file system is not initialized. Initialize the File System on the SD card using SRU. To do this, on the SRU main window, choose **File Explorer ▶ Initialize File System**.

Bluetooth Problems

The following are some of the most commonly encountered error messages and other problems.

SRU error message: Can't find receiver

- The receiver is turned off.
 - Ensure the receiver has power and is turned on.
- Bluetooth is not turned on; the BT LED is off.
 - Reset the receiver to the factory default settings by pressing the Power button for 10 to 15 seconds.
 - You can also turn on power to Bluetooth using SRU. To do this, on the SRU main window, choose **Receiver Settings ▶ Bluetooth**.
- There is interference.
 - Move the receiver, controller, or computer to an unobstructed location.
- The receiver is too far away.
 - Move the devices closer together.
- The receiver is already connected via Bluetooth to another device.
 - Disconnect the receiver from the other controller or computer.
- The receiver port used for connection is not in Command mode.
 - a. Connect the receiver to a computer and open SRU [see “Connection” in the *Sokkia Receiver Utility (SRU) Reference Manual*].

- b. Click **Configuration ▶ Receiver ▶ Ports**.
- c. Change the **Input Mode** for the Bluetooth serial port used for connection to **cmd**.



This is the most common cause for this error message. Use SRU to double check the settings for the connection port.

SRU error message: Open COM# port failed: Access is denied

- Another application uses the computer port dedicated for connection.
 - Close the application, and then re-connect.
 - Connect the receiver via another, unused computer port.

After searching for available devices, none are discovered

- The receiver is not receiving power.
 - Check that the receiver is getting power and is turned on.
 - Check that the optional power cable is correctly attached to the port if one is being used.
 - Unplug the cable, then securely and properly reconnect it to the receiver.
 - If the power cable is damaged, contact a Dealer to purchase a new cable.

Can see the icon for the receiver's Bluetooth module on the computer screen, but cannot connect to it

- Device security settings probably differ.
 - Make sure the Bluetooth enabled devices use the same security settings.

- Bluetooth module settings may have changed.
 - a. If the settings are changed for the Bluetooth module, remove it from the list of discovered Bluetooth devices using the Bluetooth manager program (supplied with the device used to manage the receiver).
 - b. Repeat the search.

SRU Problems

The following is the most commonly encountered SRU problem.

SRU cannot connect to the receiver

- The receiver is turned off.
 - Ensure the receiver has power and is turned on.
- If using a cable, the cable's connectors are improperly attached.
 - Check that the cable connector is attached to the correct serial port.
 - Unplug the cable, then securely and properly reconnect it to the receiver.
- If using a cable, the cable is damaged.
 - Use an undamaged cable.
 - Contact a dealer to purchase a new cable.
- If using Bluetooth wireless technology, the incorrect port is selected.
 - Use a computer or receiver that has Bluetooth wireless technology enabled/installed.
 - Make sure the computer and receiver use the correct ports for communication. For the GRX2 receiver, this is Bluetooth serial port A (btsp\A).

Cleaning and Storing the Receiver

- Use a clean cloth moistened with neutral detergent or water.
- Never use an abrasive cleaner, ether, thinner benzene, or other solvents.
- Always make sure the receiver is completely dry before storing it. Dry any moisture with a soft, clean cloth.

Getting Customer Support

If the troubleshooting hints and tips in this operator's manual fail to remedy the problem, contact Sokkia Support. For contact information, see "Getting Technical Support" on page 7.

Specifications

This chapter provides specifications for the GRX2 and its internal components. This list of recommendations is based on testing results available to date and should not be considered a comprehensive list. The receiver is capable of working with SD/SDHC cards with a storage capacity of up to 32GB.

General Details

Table 4. Receiver General Specifications

Physical	
Enclosure	Magnesium alloy
Color	Sokkia gray and blue (bumper)
Dimensions	184.0mm X 95.0mm (diameter x Height)
Weight	1.00kg (without battery and radio)
Antenna	Internal micro center
Battery	Built-in, detachable/replaceable
Controller	External
Mounting	5/8-11, quick release

Table 4. Receiver General Specifications (Continued)

Seals	Silicone
Keys	One key: Power- On/Off, multi-function
LEDs	22 LEDs Receiver Health Scheduler Status Available Power Bar Battery Status Satellite Tracking Bar Position Status Memory Capacity Bar File Status Wireless Status Radio Status Serial Port Status
Environment	
Operating temperature	-20 to +65°C (Battery) / -40 to +65°C (Ext.) / -20 to +55 (w/ UHF modem module)
Storage temperature	-45°C to +70°C
Humidity	100% condensing
Water/Dust-proof	IP67 with all connector caps closed.

Table 4. Receiver General Specifications (Continued)

Power	
Built in battery	BDC70 Li-ion 5.2Ah (Typical) / 7.2VDC
Battery weight	195g
Battery charging time	4 hours
Operating time	Over 7.5 hours (20C / static data logging / w BT)
External power	1 port
Input voltage	6.7 to 18 VDC
Consumption	4W (w/o UHF modem)
Battery charge	Use CDC68
On-board	Backup battery for NVRAM and RTC storage; Operation for approximately 100 days.
I/O	
Communication Ports	Bluetooth and (Serial) RS-232C

Table 4. Receiver General Specifications (Continued)

Port specifications	COM1: 4,800 to 115,200 bps (RS Level) 115,200 bps (default) Bluetooth: 115,200 bps (SPP/Single Channel mode)
Modem Antenna	BNC
NMEA	
NMEA version	Ver. 2.1, 2.2, 2.3, 3.0
Messages	GGA, GLL, GNS, GRS, GSA, GST, GSV, HDT, RMC, VTG, ZDA, ROT, GMP
Output interval	Up to 20Hz
DGPS	
Correction format	RTCM SC104 Ver 2.1, 2.2, 2.3, 3.0, 3.1
RTCM message type	1, 3, 9, 31, 32, 34; user selectable
Process interval	Up to 20Hz
Output interval for RTCM correction data	Up to 20Hz
Elevation mask	0 to 90 degrees (independent of data logging)

Table 4. Receiver General Specifications (Continued)

RTK	
Correction format ^a	CMR/CMR+, RTCM SC104 Ver 2.2, 2.3, 3.0 or 3.1
RTCM message type	User selectable
Ambiguity initialize	OTF (L1, L1/L2)
Baseline Length	Up to 50km
Initialize time	> 15 seconds, typical
Output interval for CMR/RTCM	Up to 20Hz
Elevation	0 to 90 degrees (independent of data logging)
Solution mode	Delay (synchronization) Extrapolation (not synchronized)
Process interval	Up to 20Hz

Table 4. Receiver General Specifications (Continued)

Survey Accuracy ^b	
Static	L1 only: H: 3mm + 0.8 ppm xD V: 4mm + 1 ppm xD L1 +L2: H: 3mm + 0.5 ppm xD V: 5mm + 0.5 ppm xD
Fast Static	L1+L2: H: 3mm+0.5 ppm xD V: 5mm+0.5 ppm xD
Kinematic	L1+L2: H: 10mm+1 ppm xD V: 15mm+1 ppm xD
RTK	L1/L1 +L2: H: 10mm + 1 ppm xD V: 15mm + 1 ppm xD
DGPS	Post processing/RTCM: Typically less than 0.5m
Cold start Warm start Reacquisition	<60 sec <35 sec (typical) <1sec

- a. CMR/CMR+ is a third-party proprietary format. Use of this format is not recommended and performance cannot be guaranteed. Use of industry standard RTCM 3.x is always recommended for optimal performance.
- b. RMS Values: Accuracy depends on the number of satellites used, obstructions, satellite geometry (DOP), occupation time, multipath effects, atmospheric conditions, baseline length, survey procedures, and data quality.



Performance specifications assume a minimum of 6 GPS satellites above 15 degrees in elevation and adherence to the procedures recommended in this manual.



In areas of high multipath, during periods of large PDOP, and during periods of increased ionospheric activity, performance may degrade.



Use robust checking procedures in areas of extreme multipath or under dense foliage.

GPS Board Details

Table 5. GPS Board Specifications

Receiver Type (set by activating the proper OAF)	
Internal GNSS board: GRX2	G: GPS L1 GD: GPS L1/L2 GG:GPS/GLONASS L1 GGD: GPS/GLONASS L1/L2
Hardware type: country/region/purpose dependent	without internal radio/modem with Digital UHF II with Digital UHF II + HSPA with Digital UHF II + CDMA with FH915 with FH915+HSPA
Tracking Specifications	
Standard Channels	226 channels ^a ; Vanguard™ ASIC with patented Universal Tracking Channel Technology GPS and GLONASS, WAAS/EGNOS/MSAS/QZSS
Tracked Signals	GPS: L1, L1 C/A, L2, L2P(Y), L2C code and carrier GLONASS: L1P, L1 C/A, L2 C/A, L2P code and carrier
Tracking Functions	
Multi-path reduction	Code and Carrier

Table 5. GPS Board Specifications (Continued)

PLL/DLL/QLL	Bandwidth, order, adjustable
Smoothing interval	Code and Carrier
WAAS/EGNOS/ MSAS	Optional
Data Features	
Formats	TPS, NMEA, RTCM, CMR/CMR+
Features	Up to 20 Hz update rate for real time position and raw data (code and carrier) 10cm code phase and 0.1mm carrier phase precision RTCM SC104 version 2.1, 2.2, 2.3, 3.0, and 3.1 I/O Multiple Base RTCM Geoid and Magnetic Variation models Different DATUMs support Output of grid coordinates CMR and CMR+ support
Memory	
Internal Memory	SD/SDHC card, removable
Capacity	Dependent on capacity of the installed SD/SDHC card
Logging Interval	0.05 to 86,400 seconds, depending on purchased options

a. Includes two dedicated channels for L-Band signal tracking. The receiver does not support L-Band signal tracking.

Bluetooth Module Details

Table 6. Bluetooth Module Specifications

Range	Up to 10 m (indoor), up to 50m (outdoor)
Type	Class 1 ^a
Service classes	Miscellaneous
Supported profiles	SPP
Frequency Country Code	North America and Europe

a. For the receiver's Class 1 Bluetooth functionality to work properly, the connected device must also support Class 1 Bluetooth.

Internal Digital UHF II Modem General Specifications

For complete details regarding the digital UHF II modem, refer to the Sokkia Radio Guide Reference Manual (p/n: 1001598-01).

Table 7. GRX2 Digital UHF II Modem General Specifications

Parameter	Specification
Operating frequency range ^a	UHF 400 – 470 MHz
Modulation techniques	GMSK and 4-Level FSK (4FSK)
Protocols ^{b,c}	Satel 4FSK PDL GMSK PDL 4FSK TrimTalk GMSK
Occupied bandwidth ^a (channel spacing)	25 kHz, 20 kHz or 12.5 kHz
Data transmission rate at 25 kHz Channel Spacing	9600 bps GMSK 19200 bps 4FSK ^ψ
Data transmission rate at 20 kHz Channel Spacing	4800 bps GMSK 9600 bps 4FSK
Data transmission rate at 12.5 kHz Channel Spacing	4800 bps GMSK ^ψ 9600 bps 4FSK ^ψ
Data speed of serial interface	Max 115200 bps

Table 7. GRX2 Digital UHF II Modem General Specifications (Continued)

Parameter	Specification
Forward Error Correction	Yes
Scrambling	Yes
Communication mode	Half-Duplex
Operation modes	Transmitter Receiver Repeater

- a. Dependent on the country and region, and mode (base/rover) of operation.
- b. Use of PDL and Satel 4FSK protocols is recommended in applications where possible. Note that a minimum baud rate of 9600 bps is recommended for all RTK operations. Compatibility with TrimTalk is subject to some restrictions.
- c. The data transmission configurations indicated (protocol and channel spacing) are the only protocols that provide compliance with UHF Narrowbanding restrictions that are effective as of January 1, 2013 in the US and Canada. For more information, please see <http://transition.fcc.gov/pshs/public-safety-spectrum/narrowbanding-faq.html> for details. Similar restrictions are also in place in other global markets. Please contact your Dealer or local government radio authority to ensure you understand local compliance obligations.

Optional Cellular Module Details

This section describes the specifications of the cellular modules offered with the GRX2 receiver.

CDMA Module Specifications

Table 8. Cellular Module Specifications

General (Dual Band CDMA 1xRTT Module)	
Supported bands ^a	CDMA 800/1900 MHz
TX power	800 MHz – Class 3 (24 dBm) 1900 MHz – Class 2 (24 dBm)
Data	1x/QNC/HSPD CSD, <i>Max BR 14.4 Kbps</i>
AT command Set	N/A
Regulatory and approvals	CDG1, CDG2 FCC, IC, CCC EMC QS9000 manufacturing RoHS/WEEE

- a. Sokkia GNSS receivers equipped with integrated C24 wireless modules are authorized to operate in the US only on the Verizon™ wireless network.

HSPA Module Specifications

Table 9. Cellular Module Specifications

General (3.5G Wireless Module Quad-band GSM and UMTS/HSPA)	
Supported bands	GSM 850/900/1800/1900 MHz UMTS/HSPA 850/1900/2100 MHz
TX power	UMTS/HSPA - Class 3 (0.25 Watt) GSM 850/900 MHz – Class 4 (2 Watt) GSM 1800/1900 MHz – Class 1 (1 Watt) EDGE 850/900 MHz – Class E2 (0.5 Watt) EDGE 1800/1900 MHz – Class E2 (0.4 Watt)
Data	UMTS/HSDPA/HSUPA 3GPP, Release 6 GSM/GPRS 3GPP, Release 9 Max uplink 5.76 Mbps, max downlink 7.2 Mbps EDGE, Multi-Slot class 12 <i>CSD, Max BR 14.4 Kbps GSM, Max BR 14.4 Kbps UMTS</i>
AT command Set	GSM 07.05, 07.07

Table 9. Cellular Module Specifications

Regulatory and approvals	FCC, IC ANATEL (Brazil) PTCRB R&TTE/CE GCF RoHS/WEEE ACMA BABT
--------------------------	---

Battery (BDC70) Specifications

Table 10. Battery Specifications

General	
Nominal voltage	7.2V
Capacity	5.2Ah
Dimensions	38 (W) x 70 (D) x 40 (H) mm
Weight about	about 195g

Charger (CDC68) Specifications

Table 11. Charger Specifications

General	
Input voltage:	AC100 to 240V
Charging time per battery (at 25°C):	about 4 hours (Charging can take longer than the times stated above when temperatures are either especially high or low.)
Charging temperature range:	0°C to 40°C (32°F to 104°F)
Storage temperature range:	-20°C to 65°C (-4°F to 149°F)
Size:	94 (W) X 102 (D) X 36 (H) mm
Weight:	about 170g

Connector Specifications

The receiver has 3 external connectors; one UHF/915+ radio modem or cellular antenna connector.

UHF Radio Modem Connector

Table 12. UHF Modem Connector Specifications

Modem	Type	Signal Type	Dir	Details
UHF	BNC	Modem I/O	I/O	RF/GSM output from modem antenna

Power Connector

Rimmed in red, the power connector (on the right) is a 5-pin sealed receptacle. Table 13 gives power connector specifications.

Table 13. Power Connector Specifications

Number	Signal Name	Dir	Details
1	Power_INP	P	9 to 21 volts DC input
2	Power_INP	P	9 to 21 volts DC input
3	Power_GND	P	Ground, power return
4	Power_GND	P	Ground, power return
5	AUX_POWER	P	9 to 21 volts DC input

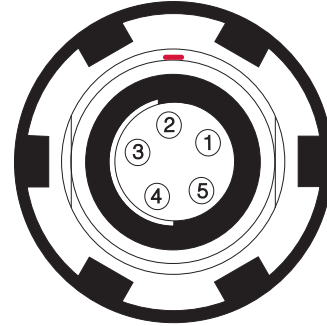

C-RS232 Serial Cable Connector

Rimmed in black, the serial C-RS232 connector (on the right) is an 8-pin sealed receptacle. Table 14 gives the C-RS232 connector specifications.

Table 14. RS232 Connector Specifications

Number	Signal Name	Dir	Details
1	–	–	Not used
2	RXD	INPUT	Receive data
3	TXD	OUTPUT	Transmit data
4	GND	I/O	Signal ground
5	GND	I/O	Signal ground
6	–	–	Not used
7	RTS	OUTPUT	Request to send



SD/SDHC Card Recommendations

Table 15 is a recommended list of SD/SDHC cards that were tested with the receiver. This list of recommendations is based on testing results available to date and should not be considered a comprehensive list. The receiver is capable of working with SD/SDHC cards with a storage capacity of up to 32GB.

Table 15. SD/SDHC Card Recommendations

Manufacturer	Model Name	Card Type	Capacity	Class	Operating Temperature (°C)
ATP	AF2GSDI (Industrial Grade)	SD	2 GB	–	-40 to 85
Transcends	TS2GSD801 (Industrial Grade)	SD	2 GB	–	-40 to 85
Panasonic	RP-SDP02G	SD	2 GB	Class 4	-25 to 85
Panasonic	RP-SDW04G	SDHC	4 GB	Class 10	-25 to 85
FujiFilm	SD-002G-C4A	SD	2 GB	Class 4	-25 to 85
Sony	SF-2N1	SD	2 GB	Class 4	-25 to 85
Toshiba	SD-E002G4	SD	2 GB	Class 4	-25 to 85
HagiwaraSys-com	HPC-SD2GT4C	SD	2 GB	Class 4	0 to 55

Table 15. SD/SDHC Card Recommendations

Manufacturer	Model Name	Card Type	Capacity	Class	Operating Temperature (°C)
Lexar	LSD2GBAC	SD	2 GB	–	0 to 55
Buffalo	RDDC-S2GC4	SD	2 GB	Class 4	0 to 55



2 GB or less SD cards can be formatted with FAT16 or FAT32 on Windows PC platform. For 4 GB SD cards, use FAT32 formatting.

Use of the listed SD/SDHC cards may cause inconsistent performance (raw data logging problem, unrecognized card, etc.) when used with HiPer and GRX receivers:

- SanDisk Standard Series (Model Name: SDSDB-4096 and SDSDB-2048)
- SanDisk Ultra Series (Model Name: SDSDH-002G)
- Transcends (Model Name: TS4GSDHC6)
- Model BSD-2G4 from I/O data exhibit good performance if formatted in FAT16 format.

Warranty

Sokkia positioning equipment are guaranteed against defective material and workmanship under normal use and application consistent with this Manual. The equipment is guaranteed for the period indicated, on the warranty card accompanying the product, starting from the date that the product is sold to the original purchaser by Sokkia's Authorized Dealers.²

During the warranty period, Sokkia will, at its option, repair or replace this product at no additional charge. Repair parts and replacement products will be furnished on an exchange basis and will be either reconditioned or new. This limited warranty does not include service to repair damage to the product resulting from an accident, disaster, misuses, abuse or modification of the product.

Warranty service may be obtained from an authorized Sokkia warranty service dealer. If this product is delivered by mail, purchaser agrees to insure the product or assume the risk of loss or damage in transit, to prepay shipping charges to the warranty service location and to use the original shipping container or equivalent. A letter should accompany the package furnishing a description of the problem and/or defect.

The purchaser's sole remedy shall be replacement as provided above. In no event shall Sokkia be liable for any damages or other claim including any claim for lost profits, lost savings or other incidental or consequential damages arising out of the use of, or inability to use, the product.

2. The warranty against defects in a Sokkia battery, charger, or cable is 90 days.

Safety Warnings

General Warnings



To comply with RF exposure requirements, maintain at least 25cm between the user and the radio modem.



TPS receivers are designed for survey and survey related uses (that is, surveying coordinates, distances, angles and depths, and recording such measurements). This product should never be used:

- Without the user thoroughly understanding this manual.
 - After disabling safety systems or altering the product.
 - With unauthorized accessories.
 - Without proper safeguards at the survey site.
 - Contrary to applicable laws, rules, and regulations.
-



TPS receivers should never be used in dangerous environments. Use in rain or snow for a limited period is permitted.

Battery Pack Warnings



Never attempt to open the casing of the detachable batteries! Lithium-Ion batteries can be dangerous if mishandled!



Do not incinerate or heat battery pack above 212 degrees fahrenheit (100 degrees celsius). Excessive heat can cause serious damage and possible explosion.



Tampering with the batteries by end users or non-factory authorized technicians will void the battery's warranty.

- Do not attempt to open the battery pack or replace it.
 - Do not disassemble the battery pack.
 - Do not charge in conditions different than specified.
 - Do not use other than the specified battery charger.
 - Do not short circuit.
 - Do not crush or modify.
-

Receiver Warnings



Tampering with the receiver by the end users or non-factory authorized technicians will void the receiver's warranty:

- Do not attempt to open the receiver and modify any of its internal components.
 - Do not charge in conditions different than specified.
 - Do not short circuit.
-

Usage Warnings



If this product has been dropped, altered, transported or shipped without proper packaging, or otherwise treated without care, erroneous measurements may occur.

The owner should periodically test this product to ensure it provides accurate measurements. Inform TPS immediately if this product does not function properly.

The following sections provide information on this product's compliance with government regulations for use.

FCC Compliance

This equipment complies with FCC radiation exposure limits set forth for uncontrolled equipment and meets the FCC radio frequency (RF) Exposure Guidelines in Supplement C to OET65. This equipment has very low levels of RF energy that it deemed to comply without maximum permissive exposure evaluation (MPE). But it is desirable that it should be installed and operated with at least 30cm and more between the radiator and person's body (excluding extremities: hands, wrists, feet and ankles).

This equipment has been tested and found to comply with the limits for a Class A digital device pursuant to part 15 of the FCC rules. These limits are designed to provide reasonable protection against harmful interference when the equipment is operated in a commercial environment. This equipment generates, uses, and can radiate radio frequency energy and, if not installed and used in accordance with the instruction manual, may cause harmful interference to radio communications. Operation of this equipment in a residential area is likely to cause harmful interference in which case the user will be required to correct the interference at his own expense.

If this equipment does cause interference to radio or television equipment reception, which can be determined by turning the equipment off and on, the user is encouraged to try to correct the interference by one or more of the following measures:

- Reorient or relocate the receiving antenna.
- Move the equipment away from the receiver.

- Plug the equipment into an outlet on a circuit different from that to which the receiver is powered.
- Consult the dealer or an experienced radio/television technician for additional suggestions.



Any changes or modifications to the equipment not expressly approved by the party responsible for compliance could void your authority to operate such equipment.

Industry Canada Compliance

This equipment complies with IC radiation exposure limits set forth for uncontrolled equipment and meets RSS-102 of the IC radio frequency (RF) exposure rules. This equipment has very low levels of RF energy that it deemed to comply without maximum permissive exposure evaluation (MPE). But it is desirable that it should be installed and operated with at least 30cm and more between the radiator and person's body (excluding extremities: hands, wrists, feet, and ankles).

This class A digital apparatus complies with Canadian ICES-003.

Cet appareil numérique de la classe A est conforme à la norme NMB-003 du Canada.

This device complies with Industry Canada licence-exempt RSS standard(s). Operation is subject to the following two conditions: (1) this device may not cause interference, and (2) this device must accept any interference, including interference that may cause undesired operation of the device.

Le présent appareil est conforme aux CNR d'Industrie Canada applicables aux appareils radio exempts de licence. L'exploitation est autorisée aux deux conditions suivantes : (1) l'appareil ne doit pas produire de brouillage, et (2) l'utilisateur de l'appareil doit accepter tout brouillage radioélectrique subi, même si le brouillage est susceptible d'en compromettre le fonctionnement.

IC RF Radiation Exposure Statement

When installing, locate or point this device away from the installer, so it does not emit RF field in excess of Health Canada's limits for the general population; Consult Safety Code 6 from Health Canada's website at www.hc-sc.gc.ca/rpb.

IC Additional Statement with Detachable Antennas

This device (with UHFII modem) has been designated to operate with the antennas listed below and have a maximum gain of 2.4dB. Antennas not included in this or having a gain greater than 2.4 dB are strictly prohibited for use with this device. The required antenna impedance is 50 ohms.

GRX2 UHFII 2.4dBi whip antenna

Manufacture/Type

420-450 MHz LAIRD or ANTENEX/G420BN

450-470 MHz LAIRD or ANTENEX/G450BN

Community of Europe Compliance

The product described in this manual is in compliance with the R&TTE and EMC directives from the European Community.

European Community Declaration of Conformity with R&TTE Directive 1999/5/EC

The following standards were applied: (R&TTE Directive 1999/5/EEC)

- EN 60950-1:2006:+A1:2009 & A1:2010
- ETSI EN 300 113-1 V1.7.1 (2011-11)
- ETSI EN 300 113-2 V1.5.1 (2011-11)
- ETSI EN 301 489-1 V1.9.2 (2011-09)
- ETSI EN 301 489-7 V1.3.1 (2005-11)

- ETSI EN 301 908-1 V5.2.1 (2011-05)
- ETSI EN 301 908-2 V5.2.1 (2011-07)
- ETSI EN 300 328 V1.7.1 (2006-10)
- ETSI EN 301 489-3 V1.4.1 (2002-08)
- ETSI EN 301 489-24 V1.4.1 (2009-05)
- ETSI EN 301 489-24 V1.5.1 (2010-10)
- ETSI EN 301 489-17 V2.1.1 (2009-05)
- ETSI EN 301 511 V9.0.2 (2003-03)
- EN 62311:2008

This equipment is intended to be marketed in the following countries:

List of National Codes:

- AT DE MT GB
- BE GR NL IS
- CY HU PL LI
- CZ IE PT NO
- DK IT SK CH
- EE LV SI BG
- FILT ES RO
- FR LU SE TR

The equipment is labelled with a CEI mark that informs users the DIG UHFII frequency range 410-470 MHz is not harmonized throughout Europe and the specific country spectrum authority should be notified before a radio modem is used.



Use of this equipment requires a license.



L'impiego di questo impianto necessita una concessione.



Das Betreiben dieser Anlage unterliegt der Konzessionspflicht.



L'utilisation de cette installation nécessite une concession.

Declaration of Conformity (R&TTE Directive 1999/5/EC)

esky [Czech]	(<i>Sokkia</i>) tímto prohlašuje, že tento (<i>GRX2</i>) je ve shod se základními požadavky a dalšími příslušnými ustanoveními směrnice 1999/5/ES.
Dansk [Danish]	Undertegnede (<i>Sokkia</i>) erklærer herved, at følgende udstyr (<i>GRX2</i>) overholder de væsentlige krav og øvrige relevante krav i direktiv 1999/5/EF.
Deutsch [German]	Hiermit erklärt (<i>Sokkia</i>) dass sich das Gerät (<i>GRX2</i>) in Übereinstimmung mit den grundlegenden Anforderungen und den übrigen einschlägigen Bestimmungen der Richtlinie 1999/5/EG befindet.
Eesti [Estonian]	Käesolevaga kinnitab (<i>Sokkia</i>) seadme (<i>GRX2</i>) vastavust direktiivi 1999/5/EÜ põhinõuetele ja nimetatud direktiivist tulenevatele teistele asjakohastele sätetele.
English	Hereby, (<i>Sokkia</i>) declares that this (<i>GRX2</i>) is in compliance with the essential requirements and other relevant provisions of Directive 1999/5/EC.
Español [Spanish]	Por medio de la presente (<i>Sokkia</i>) declara que el (<i>GRX2</i>) cumple con los requisitos esenciales y cualesquiera otras disposiciones aplicables o exigibles de la Directiva 1999/5/CE.

[Greek]	ΜΕ ΤΗΝ ΠΑΡΟΥΣΑ (<i>Topcon Positioning Systems, Inc.</i>) ΔΗΛΩΝΕΙ ΟΤΙ (<i>GRX2</i>) ΣΥΜΜΟΡΦΩΝΕΤΑΙ ΠΡΟΣ ΤΙΣ ΟΥΣΙΩΔΕΙΣ ΑΠΑΙΤΗΣΕΙΣ ΚΑΙ ΤΙΣ ΛΟΙΠΕΣ ΣΧΕΤΙΚΕΣ ΔΙΑΤΑΞΕΙΣ ΤΗΣ ΟΔΗΓΙΑΣ 1999/5/ΕΚ.
Français [French]	Par la présente (<i>Sokkia</i>) déclare que l'appareil (<i>GRX2</i>) est conforme aux exigences essentielles et aux autres dispositions pertinentes de la directive 1999/5/CE.
Italiano [Italian]	Con la presente (<i>Sokkia</i>) dichiara che questo (<i>GRX2</i>) è conforme ai requisiti essenziali ed alle altre disposizioni pertinenti stabilite dalla direttiva 1999/5/CE.
Latviski [Latvian]	Ar šo (<i>Sokkia</i>) deklar, ka (<i>GRX2</i>) atbilst Direktvas 1999/5/EK btiskajm prasbm un citiem ar to saisttajiem noteikumiem.
Lietuvi [Lithuanian]	Šiuo (<i>Sokkia</i>) deklaruoja, kad šis (<i>GRX2</i>) atitinka esminius reikalavimus ir kitas 1999/5/EB Direktyvos nuostatas.
Nederlands [Dutch]	Hierbij verklaart (<i>Sokkia</i>) dat het toestel (<i>GRX2</i>) in overeenstemming is met de essentiële eisen en de andere relevante bepalingen van richtlijn 1999/5/EG.
Malti [Maltese]	Hawnhekk, (<i>Sokkia</i>), jiddikjara li dan (<i>GRX2</i>) jikkonforma mal-tijiet essenzjali u ma provvedimenti orajn rilevanti li hemm fid-Dirrettiva 1999/5/EC.

Magyar [Hungarian]	Alulírott, (<i>Sokkia</i>) nyilatkozom, hogy a (<i>GRX2</i>) megfelel a vonatkozó alapvető követelményeknek és az 1999/5/EC irányelv egyéb előírásainak.
Polski [Polish]	Niniejszym, (<i>Sokkia</i>), deklaruje, że (<i>GRX2</i>) spełnia wymagania zasadnicze oraz stosowne postanowienia zawarte Dyrektywie 1999/5/EC.
Português [Portugues]	(<i>Sokkia</i>) declara que este (<i>GRX2</i>) está conforme com os requisitos essenciais e outras disposições da Directiva 1999/5/CE.
Slovensko [Slovenian]	(<i>Sokkia</i>) izjavlja, da je ta (<i>GRX2</i>) v skladu z bistvenimi zahtevami in ostalimi relevantnimi določili direktive 1999/5/ES.
Slovenský [Slovak]	(<i>Sokkia</i>) týmto vyhlasuje, že (<i>GRX2</i>) spa základné požiadavky a všetky príslušné ustanovenia Smernice 1999/5/ES.
Suomi [Finnish]	(<i>Sokkia</i>) vakuuttaa täten että (<i>GRX2</i>) tyyppinen laite on direktiivin 1999/5/EY oleellisten vaatimusten ja sitä koskevien direktiivin muiden ehtojen mukainen.
Svenska [Swedish]	Härmed intygar (<i>Sokkia</i>) att denna (<i>GRX2</i>) står i överensstämmelse med de väsentliga egenskapskrav och övriga relevanta bestämmelser som framgår av direktiv 1999/5/EG.

WEEE Directive

Following information is for EU-member states only:

The use of the symbol below indicates that this product may not be treated as household waste. By ensuring this product is disposed of correctly, to help prevent potential negative consequences for the environment and human health, which could otherwise be caused by inappropriate waste handling of this product. For more detailed information about the take-back and recycling of this product, please contact a supplier where you purchased the product or consult.



Bluetooth Transmission Statements/Compliance

This Bluetooth device is compliant to the following profiles of the core spec version 2.1/2.1+EDR:

- Baseband
- HCI
- Link Manager
- Radio

The radio has been tested using the maximum antenna gain of 2.3 dBi and the Bluetooth qualification is valid for any antenna with the same or less gain.

Glossary

B

Base Station – A GNSS receiver set up over a known point, which is used to derive correction information for nearby Rover (mobile) GNSS receivers.

Bluetooth® – Often used in place of cables, Bluetooth is open wireless technology for exchanging data over short distances from fixed and mobile devices.

C

COMPASS – BeiDou Navigation Satellite System maintained and operated by China.

G

G – GPS L1 only

GALILEO – The satellite system currently being maintained and operated by the European Union (EU) and European Space Agency (ESA).

GD – GPS dual frequency

GG – GPS + GLONASS L1 only

GGD – GPS + GLONASS Dual Frequency signal tracking.

GLONASS – The GLObal NAVigation Satellite System maintained and operated by the Russian Federation.

GNSS – Global Navigation Satellite Systems, such as GPS and GLONASS.

GPS – The Global Positioning System maintained and operated by the United States Department of Defense.

L

L1 – The primary L-band carrier used by GPS and GLONASS satellites to transmit satellite data.

L2 – The secondary L-band carrier used by GPS and GLONASS satellites to transmit satellite data.

Light-Emitting Diode (LED) – Used as indicator lights on the receiver to display the status of the receiver's components and control receiver operations.

M

MAGNET Field™ – Data controller software that is part of the MAGNET software system.

MAGNET Office™ – Post-processing and CAD solution software for surveying and grade application. It is part of the MAGNET software system.

MINTER – The receiver's Minimum INTERface used to display and control data input and output.

N

Network RTK – Collects satellite observations from the reference stations within the network and sends RTK corrections to the Rover.

O

Option Authorization File (OAF) – This enables the specific features that a customer purchases.

P

Phase Center of Antenna – The point from which the electromagnetic radiation spreads spherically outward, with the phase of the signal being equal at any point on the sphere.

Pocket-3D – Field controller software by Sokkia that supports both GNSS and TS.

R

Real-Time Kinematic (RTK) – A precise method of real-time surveying. RTK enables you to check the measurement quality without having to process the data.

Root Mean Square (RMS) – Statistical measure of the magnitude of a varying quantity.

Rover – A mobile GNSS receiver and data collector used for determining location in the field.

S

Satellite-Based Augmentation Systems (SBAS) – Complements existing global navigation systems. SBAS transmits differential corrections and messages for navigation satellites that are within sight of a network or reference stations in a wide area, such as a continent.

Sokkia Receiver Utility (SRU) – Hardware configuration software for receivers and peripheral devices. SRU is included on the GPS+ Software CD that accompanied your receiver.

Static Survey – Typically uses a network or multiple baseline approach for positioning. This method provides the highest accuracy and requires the longest observation times.

U

Universal Serial Bus (USB) – A connection standard used by devices, such as a receiver, controller, computer, etc.



**ISO 9001:2000
FM 68448**

GRX2 Operator's Manual
P/N: 1001826-01 Rev B 12/12

©2012 Topcon Positioning Systems, Inc.
Concerns regarding this Sokkia product may be sent to Service and Repair Department,
Topcon Positioning Systems, Inc., 7400 National Drive, Livermore, California 94550
All rights reserved. No unauthorized duplication.